



Industrial Solutions Flatpanel Technology

DESIGN FOR TFT COLOR LCD MODULE

Design No.	dah070_104
Revision	Rev. 1.0
Type	10.4" 1024 x 768
Specification	
Version	Internal Revision 1.2
Date	14.02.2012
Preliminary <input checked="" type="checkbox"/>	
Final <input type="checkbox"/>	
Approved	

This typical design can be used to manufacture dedicated products at i-sft according to the mentioned specification with partial NRE cost.
Please send us a RFQ for this design and stating the number of displays to be build. We will send a formal quote including a final specification. With your formal order please also send a written approval of the final specification.
No further activities will start before formal order is processed and written approval of final specification is in!



Typical DESIGN easy to be modified

Revision	Date	Description
1.0	Q1/08	First Draft

Specification

Revision	Date	Description
1.0	26.05.2008	First Draft
1.1	06.03.2009	Operating and storage temperature are twisted
1.2	14.02.2012	Custom specific adaption



Typical DESIGN easy to be modified

1	DESCRIPTION.....	4
2	FEATURES.....	4
3	APPLICATIONS.....	4
4	STRUCTURE AND FUNCTIONS.....	5
5	OUTLINE OF CHARACTERISTICS.....	6
6	BLOCK DIAGRAMM	7
7	SPECIFICATIONS	8
	7-1 GENERAL SPECIFICATIONS.....	8
	7-2 ABSOLUTE MAXIMUM RATINGS.....	8
	7-3 ELECTRICAL CHARACTERISTICS	8
	7-4 INTERFACE PIN CONNECTION.....	11
	7-5 DISPLAY COLORS vs. INPUT DATA SIGNALS.....	13
	7-6 INPUT SIGNAL TIMING	14
	7-7 LVDS Rx interface timing parameter.....	15
	7-8 PIXEL CO-ORDINATES	15
	7-9 OPTICAL CHARACTERISTICS.....	16
	7-10 OUTLINE DIMENSIONS.....	19
	7-11 DEFECT SPECIFICATIONS.....	20
8	RELIABILITY TESTS.....	22
	8-1 ENVIRONMENTAL TESTS	22
	8-2 EMI/EMC TESTS.....	23
9	GENERAL PRECAUTIONS.....	24
	9-1 MOUNTING.....	24
	9-2 HANDLING.....	24
	9-3 STORAGE.....	25
	9-4 OPERATION	25
	9-5 OTHERS	25



Typical DESIGN easy to be modified



1 DESCRIPTION

I-SFT dah070_104 is a custom specific development based module and is not available on the open market.

I-SFT dah070_104 is a TFT (thin film transistor) active matrix color liquid crystal display (LCD) comprising of an amorphous silicon TFT attached to each signal electrode with circuit drivers.

I-SFT dah070_104 is an **i-sft** GmbH in-house design consisting of:

- a. **i-sft** specific third party manufactured LCD-Glass-Matrix (NOT available in retail).
- b. **i-sft** customized backlight emitting a display surface brightness typ. 1000 nits.
- c. **i-sft** custom made integrated e³ driver to control the backlight.

The 10.4 inch diagonal display area contains 1024x768 pixels and can display 256k colors.

2 FEATURES

- 10.4" XGA High-bright
- open frame
- Low power consumption
- Long life e3-technology system
- BLU - Color temperature 9000K
- High contrast ratio, high aperture structure
- Ultra-wide temperature range
- High shock and vibration
- Interlocking connector
- Integrated e³ driver for driving backlight
- LVDS interface

3 APPLICATIONS

Industrial application



Typical DESIGN easy to be modified



4 STRUCTURE AND FUNCTIONS

A TFT color LCD module comprises of a TFT LCD panel, LSIs for driving liquid crystal. The TFT LCD panel is composed of a TFT array glass substrate superimposed on a color filter glass substrate with liquid crystal filled in the narrow gap between two substrates.

RGB (Red, Green, Blue) data signals are sent to LCD panel drivers after modulation into suitable forms for active matrix addressing through a signal processor.

Each of the liquid crystal cells acts as an electro-optical switch that controls the incident light transmission by a signal applied to a signal electrode through the TFT switch.



5 OUTLINE OF CHARACTERISTICS

ITEM	SPECIFICATION	UNIT	NOTE
Active display area	210.432 (H) x 157.824 (V) (10.4 inch diagonal)	mm	
Driver element	a – Si TFT active matrix		
Display colours	256k		
Number of pixels	1024 x 768	pixel	
Luminance (typ.)	1000	cd/m ²	
Dimming ratio	1 : 1000		
Pixel arrangement	RGB vertical stripe		
Pixel pitch	0.2055 (H) x 0.2055 (W)	mm	
Display mode	Normally Black		
Surface treatment	Haze 25, Anti-glare & hard-coating (3H)		

Typical DESIGN easy to be modified

6 BLOCK DIAGRAMM

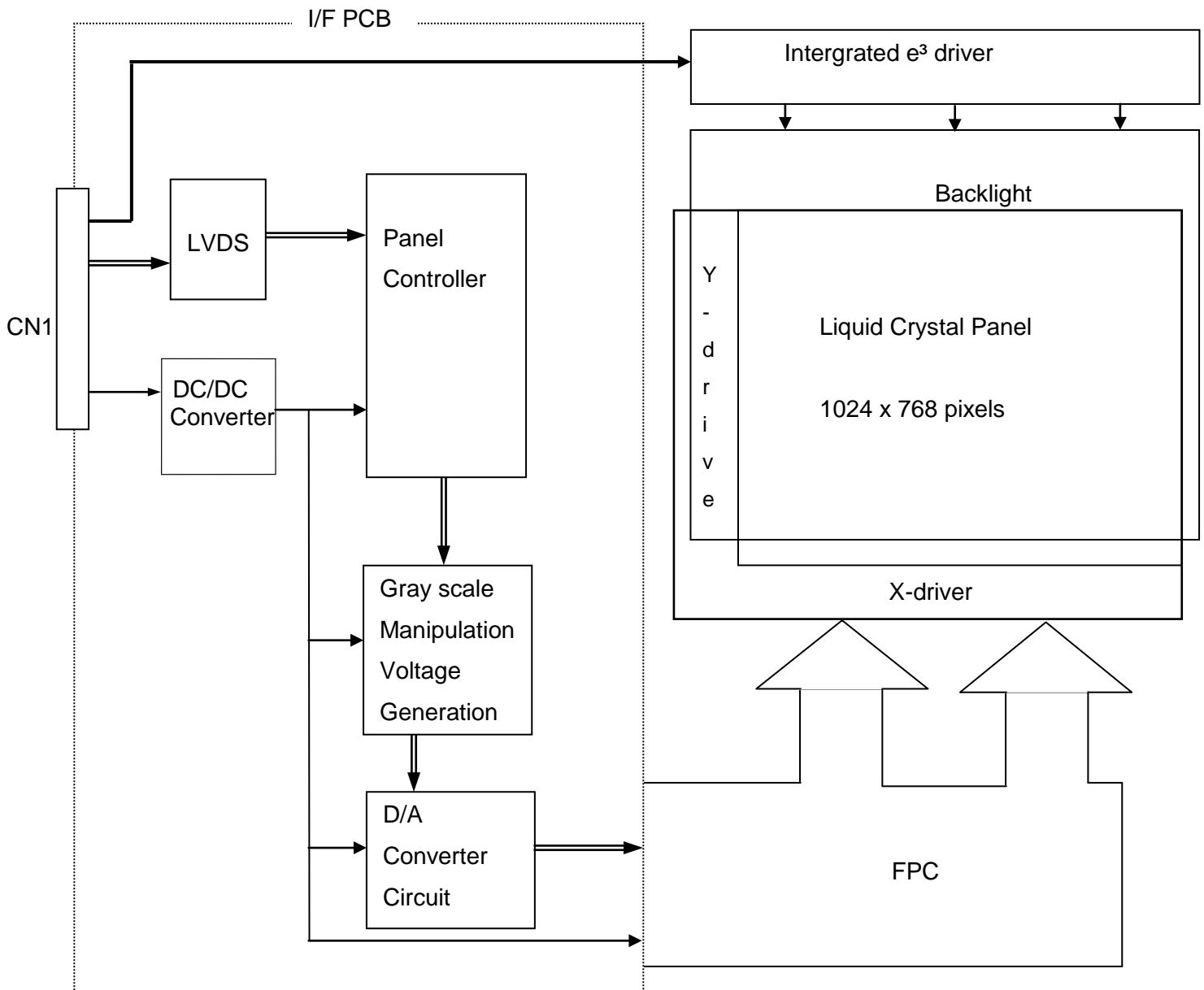



Typical DESIGN easy to be modified

7 SPECIFICATIONS

7-1 GENERAL SPECIFICATIONS

ITEM		TYP.	UNIT
Module size	Horizontal (H)	251.5	mm
	Vertical (V)	177.6	mm
	Depth (D)	23.55	mm
Weight		1300	g

7-2 ABSOLUTE MAXIMUM RATINGS

ITEM	SYMBOL	MIN.	MAX.	UNIT	NOTE
Storage temperature	T_{stg}	-45	85	°C	(1)
Operating temperature (Surface of glass)	T_{op}	-31	85	°C	(1)
Shock (operating)	S_{op}	-	50	g	(2)
Vibration (operating)	V_{op}	-	3.5	g	(3)

Note

(1) measured at center of display area (front side); as compromised, D-IC and Polarizer are excluded within the range of guarantee for operating temperature; D-IC: -10 to +75°C (Source) / -20 to 75°C (Gate); no condensation

(2) 11 ms.

(3) Random vibration according to MIL-STD810F Methode514.4

7-3 ELECTRICAL CHARACTERISTICS

(1) Logic, LCD driving

 $T_a = 25^\circ\text{C}$

Parameter	Symbol	Min.	Typ.	Max.	Unit	Remarks
-----------	--------	------	------	------	------	---------



Typical DESIGN easy to be modified

Supply voltage	V _{DD}	3.0	3.3	3.6	V	-
Supply current	I _{DD}	-	210	-	mA	Note 1
Permissible Input Ripple voltage	V _{RF}	-	-	100	mV	V _{DD} = 3.3V
Logic input "L" voltage	V _{IL}	-100	-	-	mV	V _{cm} = 1.2V typ
Logic input "H" voltage	V _{IH}	-	-	+100	mV	

Note 1: The supply voltage is measured and specified at the interface connector of LCM.

The current draw and power consumption specified is for V_{DD} = 3.3V, Frame rate = 60Hz and Clock frequency = 65MHz.

Test Pattern of power supply current

- Typ: Vertical color bar pattern
- Max: Gray 228 @ vertical 2 skip line pattern

(2) Backlight, e³ driver drivingT_a = 25°C

Parameter	Symbol	Min.	Typ.	Max.	Unit	Remarks
Supply voltage	V _{inv}	10.8	12	13.2	V	
Power consumption	P _{inv}	-	< 20	-	W	V _{inv} = 12V

SUPPLY VOLTAGE SEQUENCE

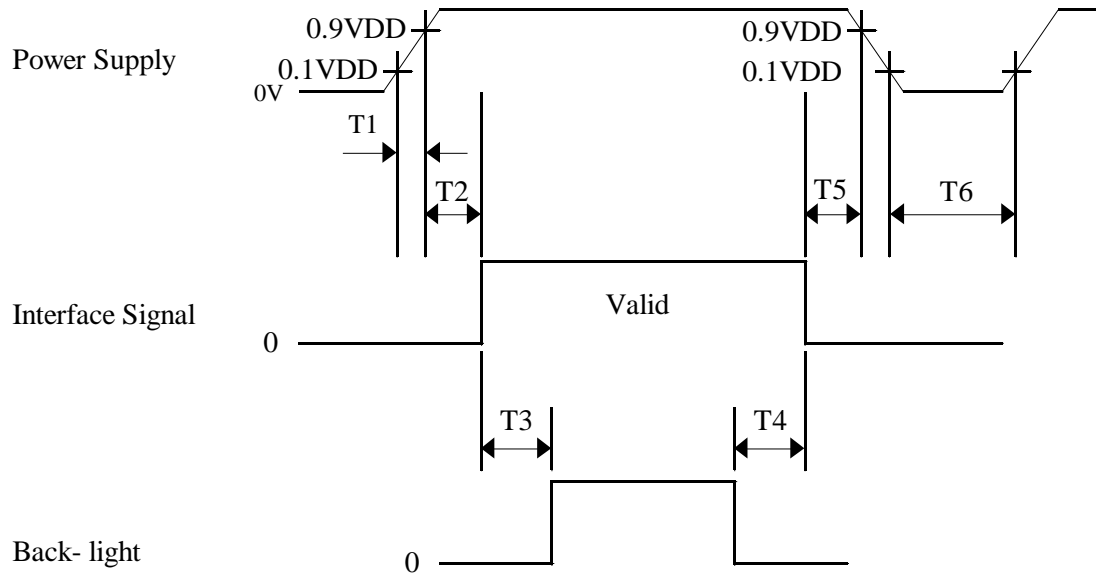

- $0 < T1 \leq 10 \text{ ms}$
- $0 < T2 \leq 50 \text{ ms}$
- $100 \text{ ms} \leq T3, T4$
- $0 < T5 \leq 50 \text{ ms}$
- $1 \text{ s} < T6$

Notes:

1. When the power supply VDD is 0V, keep the level of input signals on the low or keep high impedance.
2. Do not keep the interface signal high impedance when power is on.
3. Backlight must be turned on after power for logic and interface signal are valid.

7-4 INTERFACE PIN CONNECTION

Interface signals, power supply

Module side connector

Hirose DF14A-25P-1.25H

Mating connector

Hirose DF14-25S-1.25C

PIN	Symbol	Function
1	V _{IN}	Power supply +12 V (1)
2	V _{IN}	Power supply +12 V (1)
3	V _{IN}	Power supply +12 V (1)
4		Factory use only (Do not connect an external signal!)
5		Remote on / off GND -> off Digital dimming input PWM not connected -> on
6		Reference current output (2.5 mA) for dimming with variable resistor (1 kΩ)
7	V _{DC}	Analog dimming input 0 - 2.5 V
8	GND	(1)
9	GND	(1)
10	GND	(1)
11		not connected
12	V _{DD}	Power supply +3.3 V
13	V _{DD}	Power supply +3.3 V
14	GND	
15	GND	
16	CK+	Sampling clock (positive: +)
17	CK-	Sampling clock (negative: -)
18	IN2+	Transmission data of pixels 2 (positive: +)
19	IN2-	Transmission data of pixels 2 (negative: -)
20	IN1+	Transmission data of pixels 1 (positive: +)
21	IN1-	Transmission data of pixels 1 (negative: -)
22	IN0+	Transmission data of pixels 0 (positive: +)
23	IN0-	Transmission data of pixels 0 (negative: -)
24	GND	
25	GND	

Note

(1) for best connection use pin 1,2 and 3 parallel and pin 8,9 and 10 in parallel



7.4.1. RECOMMENDED TRANSMITTER (THC63LVDM83A or equivalent) TO I-SFT D-sh068-m INTERFACE ASSIGNMENT

DS90CF363				I-SFT			
Transmitter		Input signal (graphics controller output signal)		Output signal symbol	Interface		
Pin No	Pin No	Symbol	Function		Pin	Symbol	
51	48	R0	red pixels display data (LSB)	OUT0- OUT0+	No. 23	IN0-	
52		R1	red pixels display data		No. 22	IN0+	
54		R2	red pixels display data				
55		R3	red pixels display data				
56		R4	red pixels display data				
3	47	R5	red pixels display data (MSB)	OUT1- OUT1+	No. 21	IN1-	
4		G0	green pixels display data (LSB)		No. 20	IN1+	
6		G1	green pixels display data				
7		G2	green pixels display data				
11		G3	green pixels display data				
12	46	G4	green pixels display data	No. 20	IN1+		
14		G5	green pixels display data (MSB)				
15	45	B0	blue pixels display data (LSB)	No. 19	IN2-		
19		B1	blue pixels display data			No. 18	IN2+
20		B2	blue pixels display data				
22	42	B3	blue pixels display data	No. 18	IN2+		
23		B4	blue pixels display data				
24		B5	blue pixels display data (MSB)				
27	41	HSYNC		No. 17	CK-		
28		VSYNC				No. 16	CK+
30		DE	compound synchronization signal				
31	40	NCLK	data sampling clock	CLK OUT-	No. 17	CK-	
	31			CLK OUT+	No. 16	CK+	

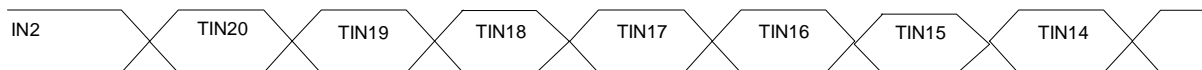
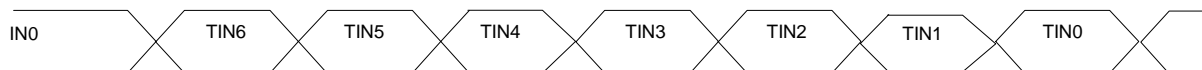



Typical DESIGN easy to be modified

7-5 DISPLAY COLORS vs. INPUT DATA SIGNALS

Display colors		Data signal(0: Low level, 1: High level)																	
		R5	R4	R3	R2	R1	R0	G5	G4	G3	G2	G1	G0	B5	B4	B3	B2	B1	B0
Basic colors	Black	0	0	0	0	0	0	0	0	0	0	0	0	0	0	0	0	0	0
	Blue	0	0	0	0	0	0	0	0	0	0	0	0	1	1	1	1	1	1
	Red	1	1	1	1	1	1	0	0	0	0	0	0	0	0	0	0	0	0
	Magenta	1	1	1	1	1	1	0	0	0	0	0	0	1	1	1	1	1	1
	Green	0	0	0	0	0	0	1	1	1	1	1	1	0	0	0	0	0	0
	Cyan	0	0	0	0	0	0	1	1	1	1	1	1	1	1	1	1	1	1
	Yellow	1	1	1	1	1	1	1	1	1	1	1	1	0	0	0	0	0	0
	White	1	1	1	1	1	1	1	1	1	1	1	1	1	1	1	1	1	1
Red grayscale	Black	0	0	0	0	0	0	0	0	0	0	0	0	0	0	0	0	0	0
		0	0	0	0	0	1	0	0	0	0	0	0	0	0	0	0	0	0
	dark	0	0	0	0	1	0	0	0	0	0	0	0	0	0	0	0	0	0
	↑																		
	↓																		
	bright	1	1	1	1	0	1	0	0	0	0	0	0	0	0	0	0	0	0
	1	1	1	1	1	0	0	0	0	0	0	0	0	0	0	0	0	0	
	Red	1	1	1	1	1	1	0	0	0	0	0	0	0	0	0	0	0	0
Green grayscale	Black	0	0	0	0	0	0	0	0	0	0	0	0	0	0	0	0	0	0
		0	0	0	0	0	0	0	0	0	0	0	1	0	0	0	0	0	0
	dark	0	0	0	0	0	0	0	0	0	0	1	0	0	0	0	0	0	0
	↑																		
	↓																		
	bright	0	0	0	0	0	0	1	1	1	1	0	1	0	0	0	0	0	0
	0	0	0	0	0	0	1	1	1	1	1	0	0	0	0	0	0	0	
	Green	0	0	0	0	0	0	1	1	1	1	1	1	0	0	0	0	0	0
Blue grayscale	Black	0	0	0	0	0	0	0	0	0	0	0	0	0	0	0	0	0	0
		0	0	0	0	0	0	0	0	0	0	0	0	0	0	0	0	0	1
	dark	0	0	0	0	0	0	0	0	0	0	0	0	0	0	0	0	1	0
	↑																		
	↓																		
	bright	0	0	0	0	0	0	0	0	0	0	0	0	1	1	1	1	0	1
	0	0	0	0	0	0	0	0	0	0	0	0	1	1	1	1	1	0	
	Blue	0	0	0	0	0	0	0	0	0	0	0	0	1	1	1	1	1	1

note: colors are developed in combination with 6 bit signals (64 steps in grayscale) of each primary red, green, and blue color.

This process can result in up to 262,144 (64×64×64) colors.

7-6 INPUT SIGNAL TIMING

Item	Symbol	MIN	TYP	MAX	Unit	Note
Frame Period	T1	772	806	1022	lines	
Vertical Display Term	T2	768	768	768	lines	
One Line Scanning Time	T3	1100	1344	2046	clocks	
Horizontal Display Term	T4	1024	1024	1024	clocks	
Clock Period	1/T5	-	65	80	MHz	

Note: The I-SFT D-sh068-m is operated by the only DE (data enable) mode (LVDS Transmitter Input)

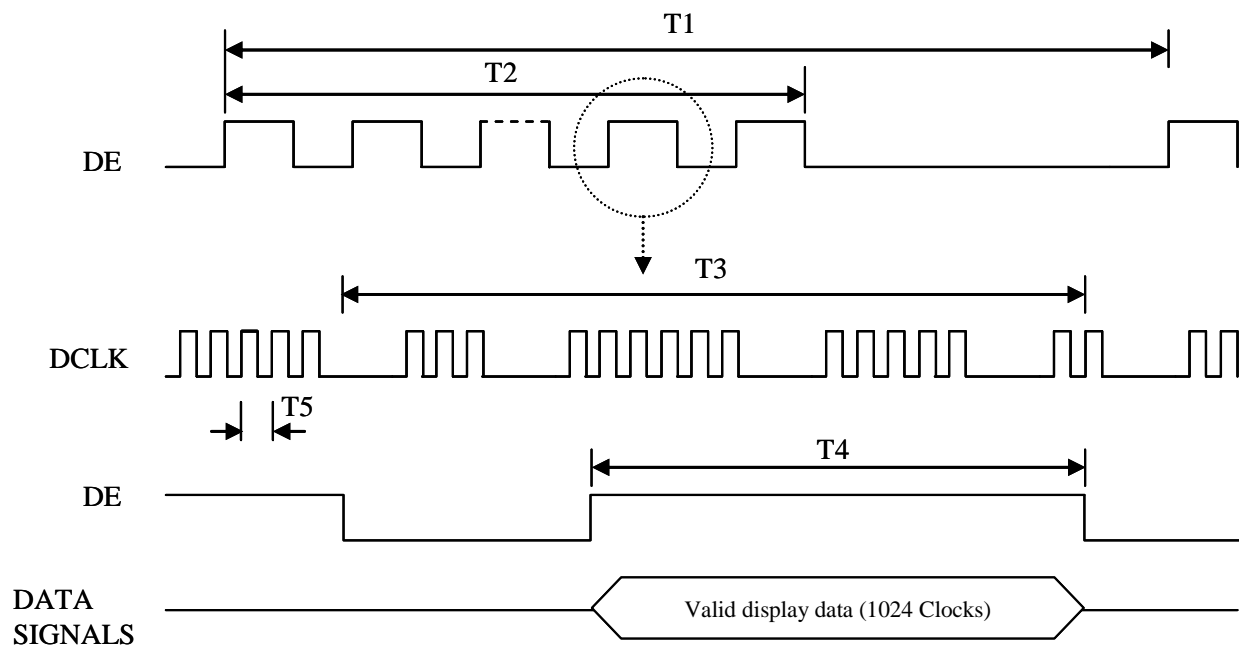

7-7 LVDS Rx interface timing parameter

specification of the LVDS Rx interface timing parameter
<LVDS Rx Interface Timing Specification>

Item	Symbol	Min	Typ	Max	Unit	Remark
CLKIN Period	tRCIP	12.5	15.38	-	nsec	
Input Data 0	tRIP1	-0.4	0.0	+0.4	nsec	
Input Data 1	tRIP0	1*tRCIP/7 -0.4	1*tRCIP/7	1*tRCIP/7 +0.4	nsec	
Input Data 2	tRIP6	2*tRCIP/7 -0.4	2*tRCIP/7	2*tRCIP/7 +0.4	nsec	
Input Data 3	tRIP5	3*tRCIP/7 -0.4	3*tRCIP/7	3*tRCIP/7 +0.4	nsec	
Input Data 4	tRIP4	4*tRCIP/7 -0.4	4*tRCIP/7	4*tRCIP/7 +0.4	nsec	
Input Data 5	tRIP3	5*tRCIP/7 -0.4	5*tRCIP/7	5*tRCIP/7 +0.4	nsec	
Input Data 6	tRIP2	6*tRCIP/7 -0.4	6*tRCIP/7	6*tRCIP/7 +0.4	nsec	

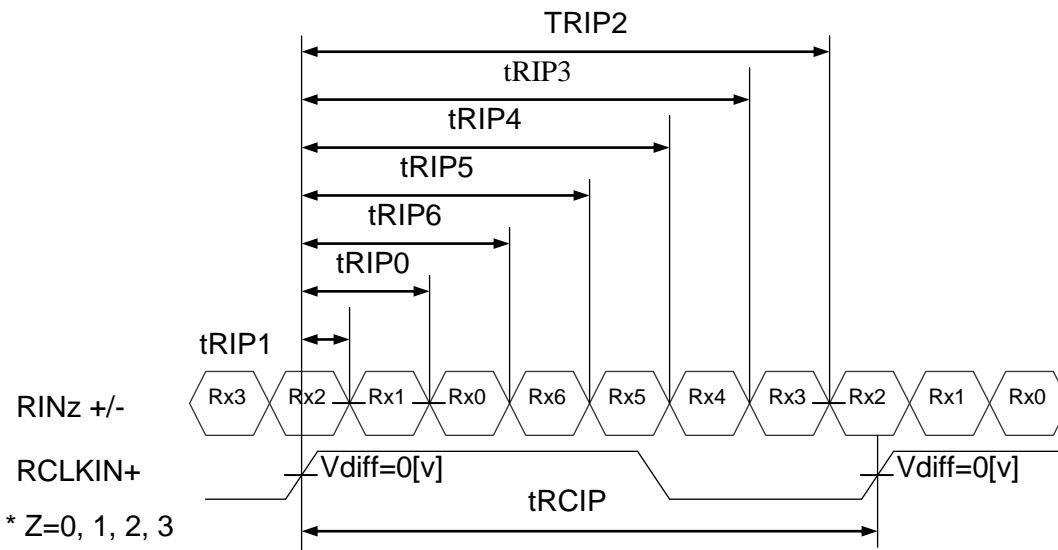

* Vdiff = (RINz+)-(RINz-), (RCLKIN+)-(RCLKIN-)

7-8 PIXEL CO-ORDINATES



Normal scan

D(1,1)	D(2,1)		D(X,1)		D(1023,1)	D(1024,1)
D(1,1)	D(1,1)		D(X,1)		D(1023,1)	D(1024,1)
D(1,Y)	D(1,Y)		D(X,Y)		D(1023,Y)	D(1024,Y)
D(1,767)	D(1,767)		D(X,767)		D(1023,767)	D(1024,767)
D(1,768)	D(1,768)		D(X,768)		D(1023,768)	D(1024,768)

7-9 OPTICAL CHARACTERISTICS

Measuring equipment:

Luminance: TOPCON BM-7

Viewing Angle, Contrast: ELDIM EZContrast 160D

Ta = 25°C ± 5°C

Parameter		Symbol	Condition	Min.	Typ.	Max.	Unit	Remark
Viewing angle range	Horizontal	∅x+	CR>10, ∅y = ±0°	-	80	-	deg.	note 1
		∅x-	CR>10, ∅y = ±0°	-	80	-	deg.	note 1
	Vertical	∅y+	CR>10, ∅x = ±0°	-	80	-	deg.	note 1
		∅y-	CR>10, ∅x = ±0°	-	80	-	deg.	note 1
Contrast ratio		CR	∅y=0°, ∅x=±0°	-	900:1	-	-	note 2
Response time		Ttotal	TR + TF	-	-	28	ms	note 3
Luminance (centre of screen)		Lw	at center v(abs) at center v(λ)	950	1200 1000		cd/m ²	note 4
Dimming range		DR			1000:1			

Note 1: Definitions of viewing angle are as follows. (Matrix facing up, connector on the right side)

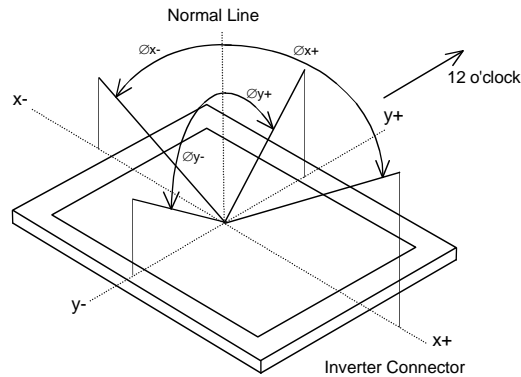

Note 2: The contrast ratio is calculated by using the following formula:

$$\text{Contrast ratio} = \frac{\text{Brightness (Luminance) with all pixels in "White"}}{\text{Brightness (Luminance) with all pixels in "Black"}}$$

The brightness is measured in a darkroom.

Note 3: Definition of response time is as follows.

Photo detector output signal is measured when the brightness changes "white" to "black". Response time is the time between 10% and 90% of the photo detector output amplitude.

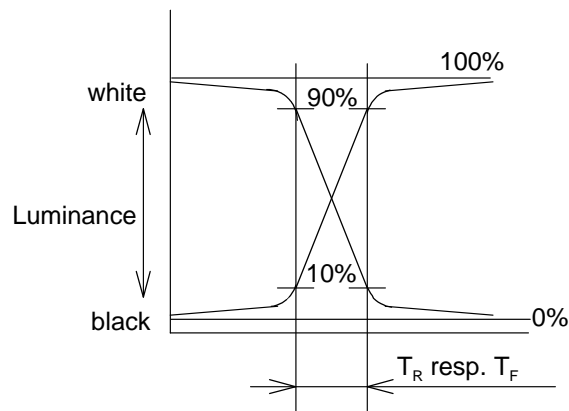

Typical DESIGN easy to be modified

Note 4: Brightness measurements setup.

Measurement should be executed in a dark room 30 minutes
after lighting the backlight. Matrix: on state.

The brightness is measured at the centre of the screen surface.

Environmental conditions: Temperature should be 25 ± 2 °C. Ensure there is sufficient
heat flow / air circulation is given

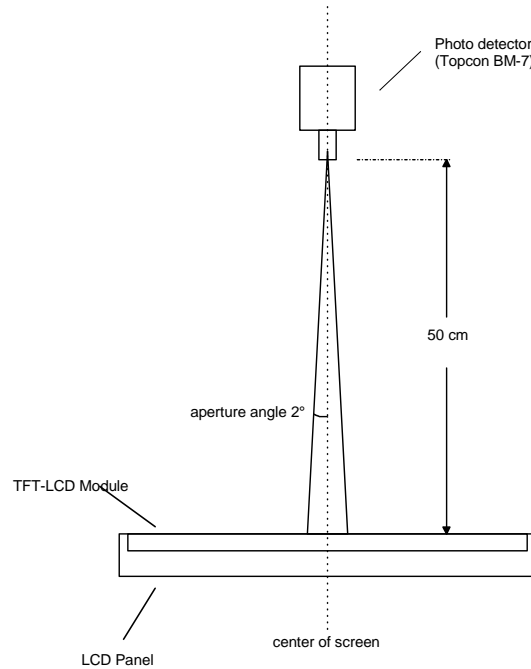

Typical DESIGN easy to be modified

7-10 OUTLINE DIMENSIONS

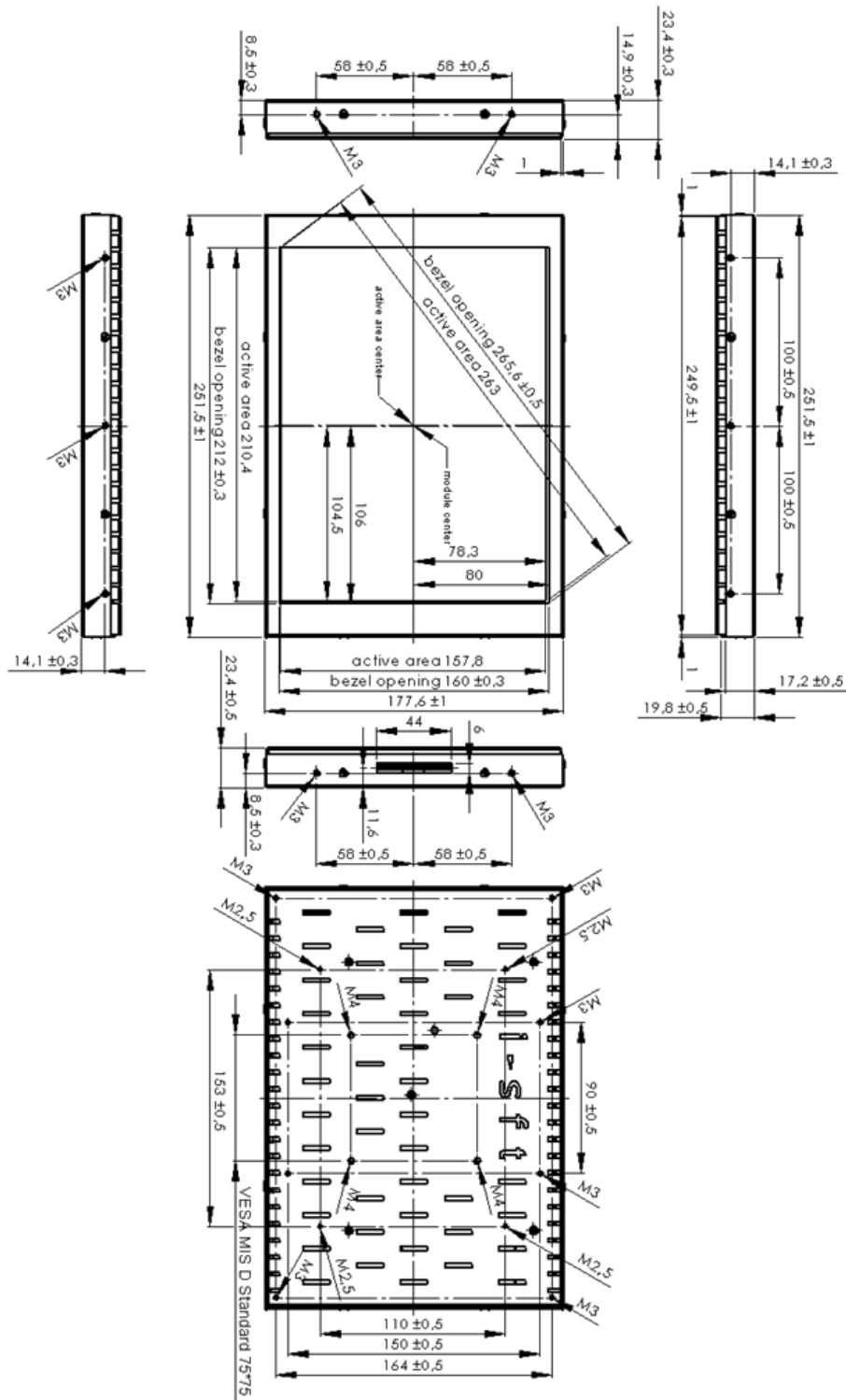

tolerances in DIN ISO 2768 T1 class m

7-11 DEFECT SPECIFICATIONS

a) Inspection conditions

Distance : the distance between the inspector's eye and the LCD panel is 20cm.

Illumination : the distance between a 20-W fluorescent lamp and the LCD panel is 25-30 cm.

Temperature : Room temperature is 25C°±5C°.

Viewing angle:

Display specifications : -20° ≤ θx ≤ +20°, 0° ≤ Øy ≤ +20°

Appearance specifications: -45° ≤ θx ≤ +45°, -45° ≤ Øy ≤ +45°

Measuring light conditions: Lamp: Cold Cathode Fluorescent Lamp

Chromaticity coordinates (x = 0.320, y = 0325) typ.

Luminance of backlight surface for inspection: 1200 cd/m²

b) Display specifications

Item	Specifications			
Line defect	Not allowed			
Luminous dots *1	Color	Brightness	Distance between same color dots	Quantity
	Red, Green	F + H	-	R + G ≤ 6
		F	-	R ≤ 6 , G ≤ 3
	Blue	F + H	-	≤ 6
		F	-	≤ 6
	Red, Green, Blue	F	≤ 6.5 mm *4	R, G, B ≤ 0
Linked two or *3 more dots			R, G, B ≤ 0	
Dark dots *2	Color	Distance between dark dots		Quantity
	Black	-		R + G + B ≤ 16 R, G, B ≤ 7
		Linked two dots *3	≤ 1 pair	
		Linked three or more dots *3	≤ 0	
		≤ 6.5 mm *4	≤ 0	

*1 F: Full luminous dots (Bright point independent of viewing angle)

H: Half luminous dots (Bright point dependent on viewing angle)

Luminous dots are measured while the screen is black.

*2 Dark dots are measured while the screen is illuminated with Red, Green, or Blue.

*3 Linkage means linked two or more dots.

■ (Luminous or Dark dot)

To be counted



To be uncounted



*4 ≤ 6.5 mm is considered with:

■ (:Luminous or Dark dot)

Typical DESIGN easy to be modified



	To be counted	To be uncounted
Luminous dots	Same color	Different color
Dark dots	Same screen	Different screen

*5 The dot-amounts of linkage and <6.5 mm are counted when the dots are only full luminous.

c) Appearance specifications

Item	Specifications		Quantity
	Measurement criteria		
Other objects Stains Dust (dot shape)	Average diameter(\varnothing) mm		Allowed value
	$\varnothing \leq 0.2$		all allowed
	$0.2 < \varnothing < 0.3$		≤ 10 points
	$0.3 < \varnothing \leq 0.5$		≤ 3 points
	$0.5 < \varnothing$		0 point
Other objects Stains Dust (line shape)	Width(W) mm	Length(L) mm	all allowed
	$W \leq 0.05$	-	
	$0.05 \leq W \leq 0.1$	$L < 0.7$	≤ 4 points
		$0.7 \leq L \leq 1.0$	0 point
	$0.1 < W$	-	
Polarizer Bubbles	Average diameter(\varnothing) mm		
Wrinkles Dent	$\varnothing \leq 0.5$		< 2 points
Panel dent	$\varnothing \leq 0.5$		< 2 points
Polarizer scratch	Remarkable scratches		0 point
Form	Specified labels and parts are put		

The relevant data for the values above a only valid under conditions described at 7-7 "a".



Typical DESIGN easy to be modified

8 RELIABILITY TESTS

8-1 ENVIRONMENTAL TESTS

Test item	Condition	Standart	Judgement
High temperature (operating)	71 ± 2°C, 3 days	Mil-Std 810F, Methode 501.4	No display malfunctions
High temperature (non operating)	71 ± 2°C, 7 days	Mil-Std 810F, Methode 501.4	
Low temperature (operating)	-21 ± 2°C, 24 hours	Mil-Std 810F, Methode 502.4	
Low temperature (non operating)	-33 ± 2°C, 24 hours	Mil-Std 810F, Methode 502.4	
Thermal shock			
Vibration (operating)	Random vibration	Mil-Std 810F, Methode 514.4	
Mechanical shock (operating)	50g , 11ms ±X, ±Y, ±Z directions	Mil-Std 810F, Methode 516.5	
Altitude (operating)	25.000ft, 20 min	Mil-Std 810F, Methode 500.4	
Altitude (non operating)	50.000ft, 1 hour	Mil-Std 810F, Methode 500.4	

**8-2 EMI/EMC TESTS**

Test item	Test Method	Test Result	EUT Meets Criteria
Emissions Test (operating)	EN 55022:2006 Class A	No significant level of emission found in the frequency range of 30MHz through 1000MHz.	Yes
	EN 61000-3-2:2006	All even and odd harmonics current emissions were within stipulated limits.	Yes
	EN 61000-3-3:2005	The test results did not exceed the limits specified in the test criteria.	Yes
Immunity Test (operating)	IEC 61000-4-2:2001 (ESD)	Observation during and review after test showed no effect of the ESD test on the EUT.	A*
	IEC 6100-4-3:2006 (immunity to RF field)	The EUT continued to function normally during and after test.	A*
	IEC 61000-4-4:2004 (EFT)	Observation during and review after test showed no effect of the above tests on the EUT.	A*
	IEC 61000-4-5:2006 (voltage Surge)	The EUT continued to function normally in spite of the presence of surge currents on the input power of the host device of the EUT.	A*
	IEC 6100-4-6:2006 (Conducted Immunity)	The EUT continued to function normally in spite of the presence of conducted RF on the cables of the EUT.	A*
	IEC 61000-4-8:2001 (Magnetic Field Immunity)	The EUT continued to function normally in spite of being subjected to magnetic interference.	A*
	IEC 61000-4-11:2004 (Voltage Dips)	The EUT continued to function normally during and after test.	A*
	IEC 61000-4-11:2004 (Brownouts)	The EUT continued to function normally during and after test.	A*

*No Degradation of Function



9 GENERAL PRECAUTIONS

9-1 MOUNTING

- (a) The module should be attached firmly to the system using every mounting hole. Be careful not to twist and bend the modules during mounting and operation.
- (b) To avoid the local build-up of heat, there must be a sufficient heat flow / air circulation on the rear side of the display. We recommend a minimum gap of 6 to 15 mm between the rear side of the display module and the application - depending on display size and orientation of mounting. As higher the display as wider the gap.
- (c) The length of fixation screws for the housing must not exceed 4 mm on the top, the bottom and on the sides. Length of fixation screws on the back plate must not exceed 6 mm
- (d) Refrain from strong mechanical shock and / or any force to the module, this may cause improper operation or damage to the module and e³ backlight.

9-2 HANDLING

- (a) Note that polarizer's are very fragile and could be easily damaged. Do not press or scratch the surface harder than a HB pencil lead.
- (b) Wipe off water droplets or oil immediately. If you leave the droplets for a long time, staining and discoloration may occur.
- (c) If the surface of the polarizer is dirty, clean it using some absorbent cotton or soft cloth.
- (d) The desirable cleaners are water, IPA (Isopropyl Alcohol) or Hexane. Do not use Ketone type materials (ex. Acetone), Ethyl alcohol, Toluene, Ethyl acid or Methyl chloride. It might produce a permanent damage to the polarizer due to chemical reaction.
- (e) If the liquid crystal material leaks from the panel (i.e. when broken), it should be kept away from the eyes or mouth. In case of contact with hands, legs or clothes, it must be washed away thoroughly with soap.
- (f) Protect the module from static electricity, it may cause damage to the C-MOS Gate Array IC`s.
- (g) Use finger-stalls with soft gloves in order to keep display clean during the incoming inspection and assembly process.
- (h) Do not disassemble the module.
- (i) Pins of I/F connector must not be touched directly with bare hands.



9-3 STORAGE

- (a) The module shall be stored in a dark place. It is prohibited to apply sunlight or fluorescent light during the store.

9-4 OPERATION

- (a) Do not connect, or disconnect the module in the “Power On” mode.
- (b) Power supply should always be turned on/off by following item 7.3 “ SUPPLY VOLTAGE SEQUENZE “. (see specification of your model)
- (c) Module has high frequency circuits. Sufficient suppression of electromagnetic interference shall be done by system manufacturers. Grounding and shielding methods may be important to minimize the interference.

9-5 OTHERS

- (a) Ultra-violet ray filter is necessary for outdoor operation.
- (b) Avoid condensation. It may result in improper operation or permanent damage.
- (c) Do not exceed the absolute maximum rating values (e.g. the supply voltage variation, input voltage variation, variation in part contents and environmental temperature and so on). Otherwise the module may be damaged.
- (d) If the module displays the same pattern continuously for a long period of time, image “sticking” can be seen on the screen. For proper operations avoid such conditions.
- (e) This module has its circuitry PCB’s on the rear side. Please handle carefully in order to avoid any kind of stress.