



## Industrial Solutions Flatpanel Technology

### DESIGN FOR TFT COLOR LCD MODULE

Design No.	dmh094_121
Revision	Rev. 1.0
Type	12,1" 1024 x 768
Specification	
Version	Internal Revision 0.2
Date	08.10.2012
Preliminary <input checked="" type="checkbox"/>	
Final <input type="checkbox"/>	

**This typical design can be used to manufacture dedicated products at i-sft according to the mentioned specification with partial NRE cost.**

**Please send us a RFQ for this design and stating the number of displays to be build. We will send a formal quote including a final specification. With your formal order please also send a written approval of the final specification.**

**No further activities will start before formal order is processed and written approval of final specification is in!**



Revision	Date	Description
1.0	Q2/10 08.10.2012	First Draft Specification layout update



<b>1</b>	<b>DESCRIPTION.....</b>	<b>4</b>
<b>2</b>	<b>FEATURES.....</b>	<b>4</b>
<b>3</b>	<b>APPLICATIONS.....</b>	<b>4</b>
<b>4</b>	<b>STRUCTURE AND FUNCTIONS.....</b>	<b>5</b>
<b>5</b>	<b>OUTLINE OF CHARACTERISTICS.....</b>	<b>6</b>
<b>6</b>	<b>BLOCK DIAGRAMM .....</b>	<b>7</b>
<b>7</b>	<b>SPECIFICATIONS .....</b>	<b>8</b>
	7-1 GENERAL SPECIFICATIONS.....	8
	7-2 ABSOLUTE MAXIMUM RATINGS.....	8
	7-3 ELECTRICAL CHARACTERISTICS.....	9
	7-4 INTERFACE PIN CONNECTION.....	11
	7-5 DISPLAY COLORS vs. INPUT DATA SIGNALS.....	12
	7-6 INPUT SIGNAL TIMING .....	13
	7-7 LVDS Rx interface timing parameter.....	14
	7-8 PIXEL CO-ORDINATES.....	15
	7-9 OPTICAL CHARACTERISTICS.....	15
	7-10 OUTLINE DIMENSIONS.....	18
	7-11 DEFECT SPECIFICATIONS.....	19
<b>8</b>	<b>GENERAL PRECAUTIONS.....</b>	<b>21</b>
	8-1 MOUNTING.....	21
	8-2 HANDLING.....	21
	8-3 STORAGE.....	22
	8-4 OPERATION .....	22
	8-5 OTHERS .....	22



## 1 DESCRIPTION

**I-SFT dmh094\_121** is a custom specific development based module and is not available on the open market.

**I-SFT dmh094\_121** is a TFT (thin film transistor) active matrix colour liquid crystal display (LCD) comprising of an amorphous silicon TFT attached to each signal electrode with circuit drivers.

**I-SFT dmh094\_121** is an **i-sft** GmbH in-house design consisting of:

- a. **i-sft** specific third party manufactured LCD-Glass-Matrix (NOT available in retail).
- b. **i-sft** customized backlight emitting a display surface brightness of typ. 1000 nits.
- c. **i-sft** custom made integrated e<sup>3</sup> driver to drive the backlight.

The 12.1 inch diagonal display area contains 1024×768 pixels and can display 256k colours.

## 2 FEATURES

12.1" XGA for High bright Applications

High efficiently

Long life lamp system

BLU - Colour temperature 9000K

## 3 APPLICATIONS

Industrial applications only



## 4 STRUCTURE AND FUNCTIONS

A TFT color LCD module comprises a TFT LCD panel, LSIs for driving liquid crystal. The TFT LCD panel is composed of a TFT array glass substrate superimposed on a color filter glass substrate with liquid crystal filled in the narrow gap between two substrates.

RGB (Red, Green, Blue) data signals are sent to LCD panel drivers after modulation into suitable forms for active matrix addressing through signal processor.

Each of the liquid crystal cells acts as an electro-optical switch that controls the incident light transmission by a signal applied to a signal electrode through the TFT switch.



## 5 OUTLINE OF CHARACTERISTICS

ITEM	SPECIFICATION	UNIT	NOTE
Active display area	245.76 (H) x 184.32 (V) (12.1 inch diagonal)	mm	
Driver element	a – Si TFT active matrix		
Display colours	256k		
Number of pixels	1024 x 768	pixel	
Luminance (typ.)	1000	cd/m <sup>2</sup>	
Dimming ratio	1 : 1000		
Pixel arrangement	RGB vertical stripe		
Pixel pitch	0.24 (H) x 0.24 (W)	mm	
Display mode	Normally Black		
Surface treatment	Anti-Reflective (No Haze)		

## 6 BLOCK DIAGRAMM

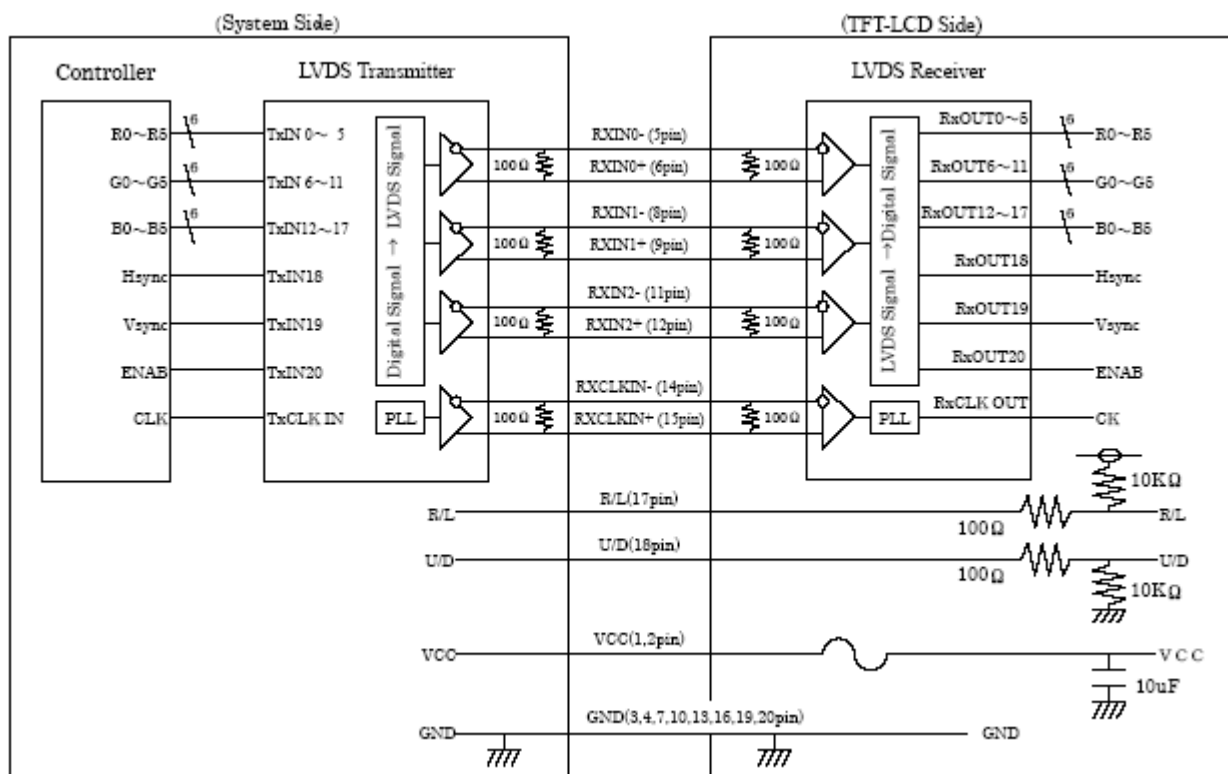



## 7 SPECIFICATIONS

### 7-1 GENERAL SPECIFICATIONS

ITEM		TYP.	UNIT
Module size	Horizontal (H)	284.8	mm
	Vertical (V)	215.4	mm
	Depth (D)	22.25	mm
Weight		1550	g

### 7-2 ABSOLUTE MAXIMUM RATINGS

ITEM	SYMBOL	MIN.	MAX.	UNIT	NOTE
Storage temperature	$T_{STG}$	-30	75	°C	(1) *
Operating temperature (Surface of glass)	$T_{OPR}$	-25	70	°C	(1) *
Shock (operating)	$S_{nop}$	-	-	g	(2)
Vibration (operating)	$V_{nop}$	-	-	g	(2)

\*target specification

#### Note

(1) measured at center of display area (front side); as compromised, D-IC and Polarizer are excluded within the range of guarantee for operating temperature; T-CON: 0 to 75°, D-IC: -10 to +75°C (Source) / -20 to 75°C (Gate), Polarizer: -20 to 80°C

(2) tbd



**7-3 ELECTRICAL CHARACTERISTICS**

## (1) Logic, LCD driving

Ta = 25°C

Parameter	Symbol	Min.	Typ.	Max.	Unit	Remarks
Supply voltage	V <sub>DD</sub>	3.0	3.3	3.6	V	-
Supply current	I <sub>DD</sub>	-	220	-	mA	Note 1
Permissible Input Ripple voltage	V <sub>RF</sub>	-	-	100	mV	V <sub>DD</sub> = 3.3V
Logic input "L" voltage	V <sub>IL</sub>	-100	-	-	mV	V <sub>cm</sub> = 1.2V typ
Logic input "H" voltage	V <sub>IH</sub>	-	-	+100	mV	

Note 1: The supply voltage is measured and specified at the interface connector of LCM.

The current draw and power consumption specified is for V<sub>DD</sub> = 3.3V, Frame rate = 60Hz and Clock frequency = 65MHz.

Test Pattern of power supply current

- Typ: Vertical color bar pattern
- Max: Gray 228 @ vertical 2 skip line pattern

(2) Backlight, e<sup>3</sup> driver driving

Ta = 25°C

Parameter	Symbol	Min.	Typ.	Max.	Unit	Remarks
Supply voltage	V <sub>inv</sub>	21.6	24	26.4	V	
Power consumption	P <sub>inv</sub>		30		W	



SUPPLY VOLTAGE SEQUENCE

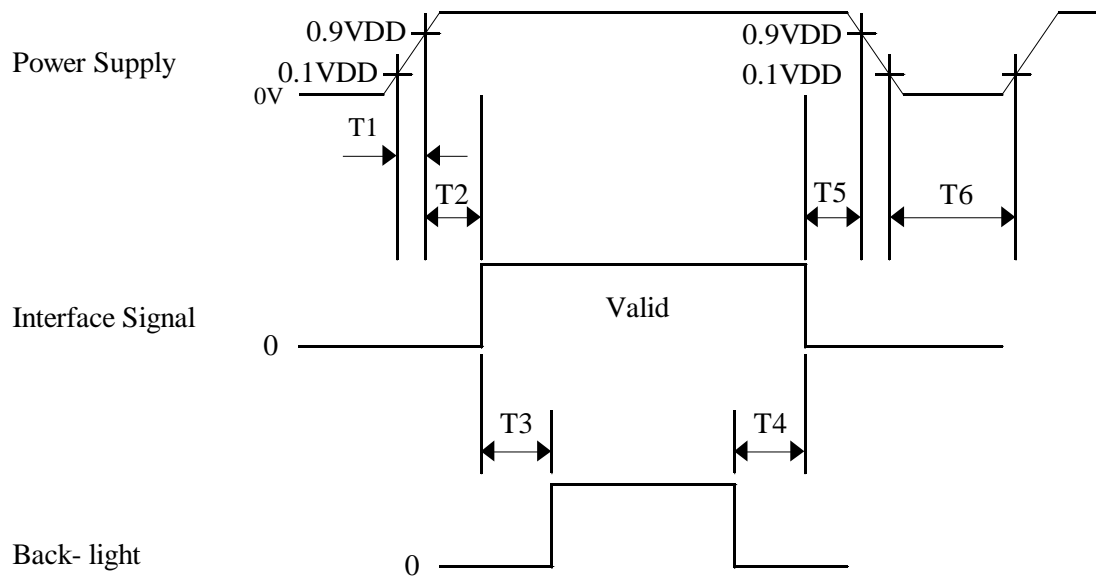

- $0 < T1 \leq 10 \text{ ms}$
- $0 < T2 \leq 50 \text{ ms}$
- $100 \text{ ms} \leq T3, T4$
- $0 \text{ ms} \leq T5$
- $150\text{ms} \leq T6$

Notes:

1. When the power supply VDD is 0V, keep the level of input signals on the low or keep high impedance.
2. Do not keep the interface signal high impedance when power is on.
3. Backlight must be turned on after power for logic and interface signal are valid.



### 7-4 INTERFACE PIN CONNECTION

Interface signals, power supply

Module side connector

Hirose DF13-30P-1.25

Mating connector

Hirose DF13-30S-1.25C

PIN	Symbol	Function
1	V <sub>DD</sub>	Power supply +3.3 V
2	V <sub>DD</sub>	Power supply +3.3 V
3	NC	Not Connected
4	GND	Ground
5	GND	Ground
6	GND	Ground
7	GND	Ground
8	IN0+	LVDS Channel 0 Positive data signal (+)
9	IN0-	LVDS Channel 0 Negative data signal (-)
10	GND	Ground
11	IN1+	LVDS Channel 1 Positive data signal (+)
12	IN1-	LVDS Channel 1 Negative data signal (-)
13	IN2+	LVDS Channel 2 Positive data signal (+)
14	IN2-	LVDS Channel 2 Negative data signal (-)
15	CLK+	LVDS Positive clock signal (+)
16	CLK-	LVDS Negative clock signal (-)
17	GND	Ground
18-23	NC	Not Connected
24	GND	Ground
25-30	NC	Not Connected

Note

(1) for best connection use pin 1 and 2 parallel and pin 4 – 7, 10, 17 and 24 in parallel



# Liquid Crystal Display Design

I-SFT dmh094\_121

Typical Design easy to be modified

## 7-5 DISPLAY COLORS vs. INPUT DATA SIGNALS

Display colors		Data signal(0: Low level, 1: High level)																	
		R5	R4	R3	R2	R1	R0	G5	G4	G3	G2	G1	G0	B5	B4	B3	B2	B1	B0
Basic colors	Black	0	0	0	0	0	0	0	0	0	0	0	0	0	0	0	0	0	0
	Blue	0	0	0	0	0	0	0	0	0	0	0	0	1	1	1	1	1	1
	Red	1	1	1	1	1	1	0	0	0	0	0	0	0	0	0	0	0	0
	Magenta	1	1	1	1	1	1	0	0	0	0	0	0	1	1	1	1	1	1
	Green	0	0	0	0	0	0	1	1	1	1	1	1	0	0	0	0	0	0
	Cyan	0	0	0	0	0	0	1	1	1	1	1	1	1	1	1	1	1	1
	Yellow	1	1	1	1	1	1	1	1	1	1	1	1	0	0	0	0	0	0
	White	1	1	1	1	1	1	1	1	1	1	1	1	1	1	1	1	1	1
Red grayscale	Black	0	0	0	0	0	0	0	0	0	0	0	0	0	0	0	0	0	0
		0	0	0	0	0	1	0	0	0	0	0	0	0	0	0	0	0	0
	dark	0	0	0	0	1	0	0	0	0	0	0	0	0	0	0	0	0	0
	↑																		
	↓																		
	bright	1	1	1	1	0	1	0	0	0	0	0	0	0	0	0	0	0	0
	1	1	1	1	1	0	0	0	0	0	0	0	0	0	0	0	0	0	
Red	1	1	1	1	1	1	0	0	0	0	0	0	0	0	0	0	0	0	
Green grayscale	Black	0	0	0	0	0	0	0	0	0	0	0	0	0	0	0	0	0	0
		0	0	0	0	0	0	0	0	0	0	0	1	0	0	0	0	0	0
	dark	0	0	0	0	0	0	0	0	0	0	1	0	0	0	0	0	0	0
	↑																		
	↓																		
	bright	0	0	0	0	0	0	1	1	1	1	0	1	0	0	0	0	0	0
	0	0	0	0	0	0	1	1	1	1	1	0	0	0	0	0	0	0	
Green	0	0	0	0	0	0	1	1	1	1	1	1	0	0	0	0	0	0	
Blue grayscale	Black	0	0	0	0	0	0	0	0	0	0	0	0	0	0	0	0	0	0
		0	0	0	0	0	0	0	0	0	0	0	0	0	0	0	0	0	1
	dark	0	0	0	0	0	0	0	0	0	0	0	0	0	0	0	0	1	0
	↑																		
	↓																		
	bright	0	0	0	0	0	0	0	0	0	0	0	0	1	1	1	1	0	1
	0	0	0	0	0	0	0	0	0	0	0	0	1	1	1	1	1	0	
Blue	0	0	0	0	0	0	0	0	0	0	0	0	1	1	1	1	1	1	

note: colors are developed in combination with 6 bit signals (64 steps in grayscale) of each primary red, green, and blue color.

This process can result in up to 262,144 (64×64×64) colors.



**7-6 INPUT SIGNAL TIMING**

Item	Symbol	MIN	TYP	MAX	Unit	Note
Frame Period	T1	772	806	1022	lines	
Vertical Display Term	T2	768	768	768	lines	
One Line Scanning Time	T3	1100	1344	2046	clocks	
Horizontal Display Term	T4	1024	1024	1024	clocks	
Clock Period	1/T5	-	65	80	MHz	

Note: The I-SFT D-sh092-m is operated by the only DE (data enable) mode (LVDS Transmitter Input)

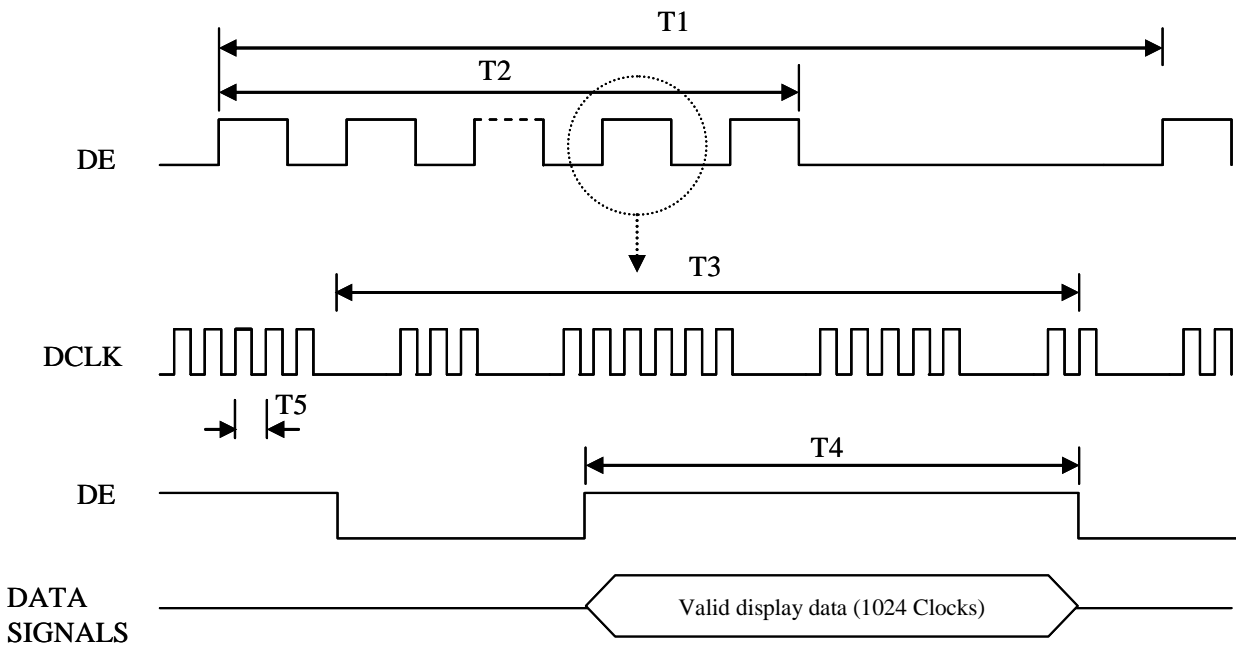



**7-7 LVDS Rx interface timing parameter**

specification of the LVDS Rx interface timing parameter  
 <LVDS Rx Interface Timing Specification>

Item	Symbol	Min	Typ	Max	Unit	Remark
CLKIN Period	tRCIP	12.5	15.38	-	nsec	
Input Data 0	tRIP1	-0.4	0.0	+0.4	nsec	
Input Data 1	tRIP0	1*tRIP/7 -0.4	1*tRIP/7	1*tRIP/7 +0.4	nsec	
Input Data 2	tRIP6	2*tRIP/7 -0.4	2*tRIP/7	2*tRIP/7 +0.4	nsec	
Input Data 3	tRIP5	3*tRIP/7 -0.4	3*tRIP/7	3*tRIP/7 +0.4	nsec	
Input Data 4	tRIP4	4*tRIP/7 -0.4	4*tRIP/7	4*tRIP/7 +0.4	nsec	
Input Data 5	tRIP3	5*tRIP/7 -0.4	5*tRIP/7	5*tRIP/7 +0.4	nsec	
Input Data 6	tRIP2	6*tRIP/7 -0.4	6*tRIP/7	6*tRIP/7 +0.4	nsec	

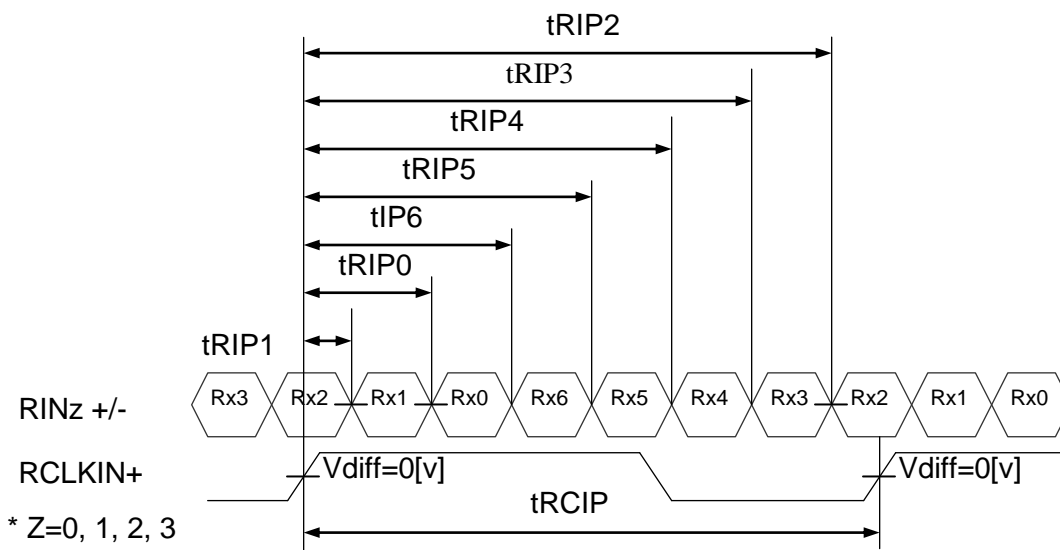

\*  $V_{diff} = (RINz+) - (RINz-), (RCLKIN+) - (RCLKIN-)$



Typical Design easy to be modified

### 7-8 PIXEL CO-ORDINATES

Normal scan

D(1,1)	D(2,1)		D(X,1)		D(1023,1)	D(1024,1)
D(1,1)	D(1,1)		D(X,1)		D(1023,1)	D(1024,1)
D(1,Y)	D(1,Y)		D(X,Y)		D(1023,Y)	D(1024,Y)
D(1,767)	D(1,767)		D(X,767)		D(1023,767)	D(1024,767)
D(1,768)	D(1,768)		D(X,768)		D(1023,768)	D(1024,768)

### 7-9 OPTICAL CHARACTERISTICS

Ta = 25°C ± 5°C

Parameter	Symbol	Condition	Min.	Typ.	Max.	Unit	Remark
Viewing angle range	Horizontal	∅x+	CR>10, ∅y = ±0°	-	80	-	deg. note 1
		∅x-	CR>10, ∅y = ±0°	-	80	-	deg. note 1
	Vertical	∅y+	CR>10, ∅x = ±0°	-	80	-	deg. note 1
		∅y-	CR>10, ∅x = ±0°	-	80	-	deg. note 1
Contrast ratio	CR	∅y=0°, ∅x=±0°	-	>750:1	-	-	note 2
Response time (at 45°C)	tpd	T <sub>r</sub> +T <sub>d</sub>	-	-	32	ms	note 3
Luminance (center of screen)	Lw	at center V <sub>abs</sub>	-	1000	-	cd/m <sup>2</sup>	note 4
		at center V(λ)	-	1200	-		note 5
Dimming range	DR			1000:1			

note 1: Definitions of viewing angle are as follows. (matrix facing up, connector on the right side)

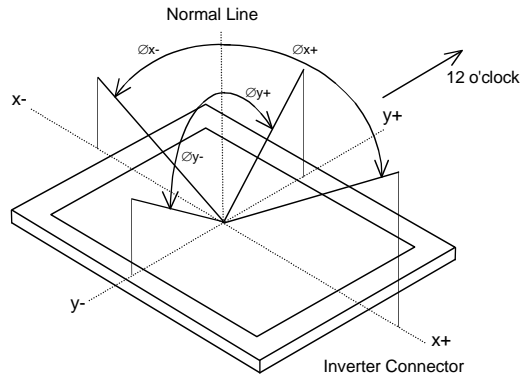

note 2: The contrast ratio is calculated by using the following formula:

$$\text{Contrast ratio} = \frac{\text{Brightness (Luminance) with all pixels in "White"}}{\text{Brightness(Luminance) with all pixels in "Black"}}$$

the brightness is measured in darkroom.

note 3: Definition of response time is as follows.

Photodetector output signal is measured when the brightness changes "white" to "black". Response time is the time between 10% and 90% of the photodetector output amplitude.

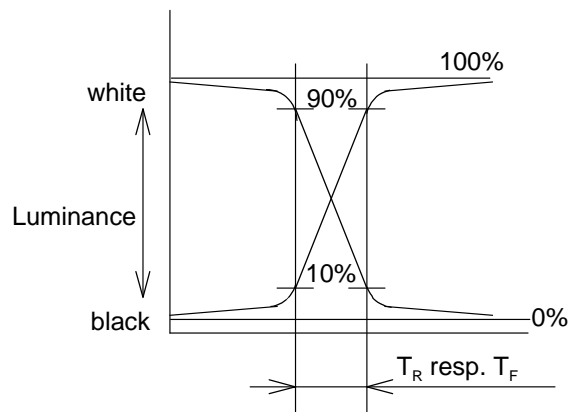

Reference data  
T<sub>a</sub> = 45°C



Typical Design easy to be modified

---

note 4: Brightness measurements setup.

measurement should be executed in a dark room 30 min.

after lightning the backlight. Matrix: off state.

The brightness is measured in the center of the screen.

Environment condition:  $T = 25 \pm 2 \text{ }^\circ\text{C}$ , it has to be assured that a sufficient heat flow / air circulation is given

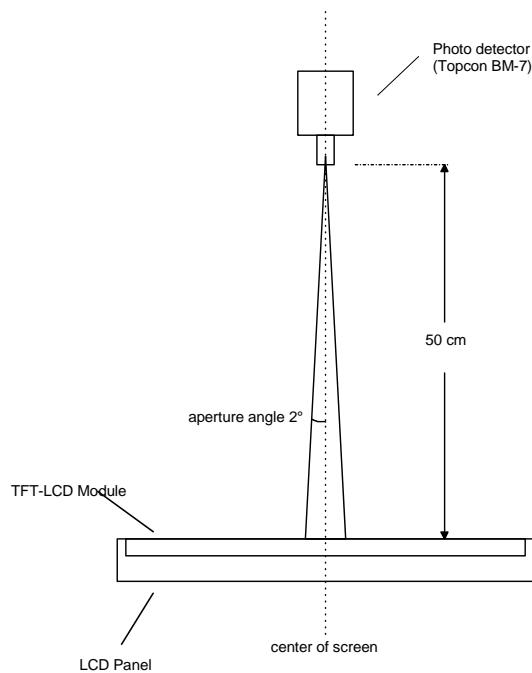

**7-10 OUTLINE DIMENSIONS**

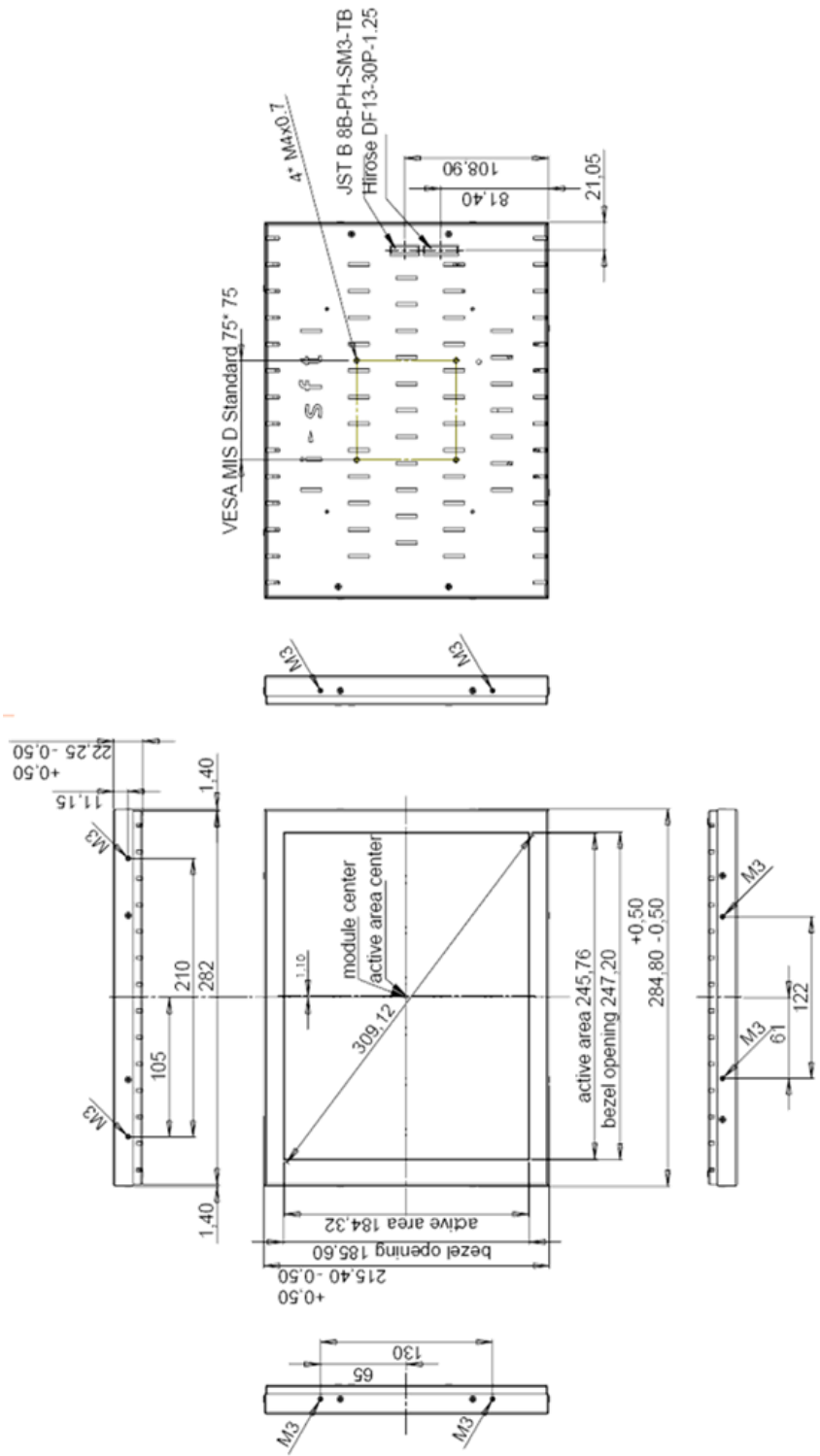

tolerances in DIN ISO 2768 T1 class m

**7-11 DEFECT SPECIFICATIONS**

a) Inspection conditions

Distance : the distance between the inspector's eye and the LCD panel is 20cm.

Illumination : the distance between a 20-W fluorescent lamp and the LCD panel is 25-30 cm.

Temperature : Room temperature is 25C°±5C°.

Viewing angle:

Display specifications :  $-20^\circ \leq \theta_x \leq +20^\circ$ ,  $0^\circ \leq \theta_y \leq +20^\circ$

Appearance specifications:  $-45^\circ \leq \theta_x \leq +45^\circ$ ,  $-45^\circ \leq \theta_y \leq +45^\circ$

Measuring light conditions: Lamp: Cold Cathode Fluorescent Lamp

Chromaticity coordinates (x = 0.320, y = 0.325) typ.

Luminance of backlight surface for inspection: 1200 cd/m<sup>2</sup>

b) Display specifications

Item	Specifications			
Line defect	Not allowed			
Luminous dots *1	Color	Brightness	Distance between same color dots	Quantity
	Red, Green	F + H	-	R + G ≤ 6
		F	-	R ≤ 6, G ≤ 3
	Blue	F + H	-	≤ 6
		F	-	≤ 6
	Red, Green, Blue	F	≤ 6.5 mm *4	R, G, B ≤ 0
Linked two or *3 more dots			R, G, B ≤ 0	
Dark dots *2	Color	Distance between dark dots		Quantity
	Black	-		R + G + B ≤ 16 R, G, B ≤ 7
		Linked two dots *3	≤ 1 pair	
		Linked three or more dots *3	≤ 0	
		≤ 6.5 mm *4	≤ 0	

\*1 F: Full luminous dots (Bright point independent of viewing angle)

H: Half luminous dots (Bright point dependent on viewing angle)

Luminous dots are measured while the screen is black.

\*2 Dark dots are measured while the screen is illuminated with Red, Green, or Blue.

\*3 Linkage means linked two or more dots.

■ ( Luminous or Dark dot)

To be counted

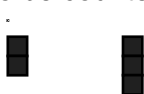

To be uncounted



\*4 ≤ 6.5 mm is considered with:

■ ( :Luminous or Dark dot)



Typical Design easy to be modified

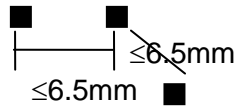

	To be counted	To be uncouncted
Luminous dots	Same color	Different color
Dark dots	Same screen	Different screen

\*5 The dot-amounts of linkage and  $\le 6.5$  mm are counted when the dots are only full luminous.

c) Appearance specifications

Item	Specifications		Quantity
	Measurement criteria		
Other objects Stains Dust (dot shape)	Average diameter( $\varnothing$ ) mm		Allowed value
	$\varnothing \le 0.2$		all allowed
	$0.2 < \varnothing < 0.3$		$\le 10$ points
	$0.3 < \varnothing \le 0.5$		$\le 3$ points
	$0.5 < \varnothing$		0 point
Other objects Stains Dust (line shape)	Linked other objects		
	Width(W) mm	Length(L) mm	all allowed
	$W \le 0.05$	-	
	$0.05 \le W \le 0.1$	$L < 0.7$	$\le 4$ points
		$0.7 \le L \le 1.0$	0 point
$0.1 < W$	-		
Polarizer Bubbles	Average diameter( $\varnothing$ ) mm		
Wrinkles Dent	$\varnothing \le 0.5$		$< 2$ points
Panel dent	$\varnothing \le 0.5$		$< 2$ points
Polarizer scratch	Remarkable scratches		0 point
Form	Specified labels and parts are put		

The relevant data for the values above a only valid under conditions described at 7-7 "a".



---

## 8 GENERAL PRECAUTIONS

### 8-1 MOUNTING

- (a) The module must be attached firmly to the system using every mounting hole. Be careful not to twist and bend the modules during mounting and operation.
- (b) To avoid the local build-up of heat, there must be a sufficient heat flow / air circulation on the rear side of the display. We recommend a minimum gap of 6 to 15 mm between the rear side of the display module and the application - depending on display size and orientation of mounting. As higher the display as wider the gap.
- (c) The length of fixation screws for the housing must not exceed \*mm on the top, the bottom and on the sides. Length of fixation screws on the backplate must not exceed \*mm - \* depend on the model
- (d) Refrain from strong mechanical shock and / or any force to the module, this may cause improper operation or damage to the module and e<sup>3</sup> backlight.

### 8-2 HANDLING

- (a) Note that polarizers are very fragile and could be easily damaged. Do not press or scratch the surface harder than a HB pencil lead.
- (b) Wipe off water droplets or oil immediately. If you leave the droplets for a long time, staining and discoloration may occur.
- (c) If the surface of the polarizer is dirty, clean it using some absorbent cotton or soft cloth.
- (d) The desirable cleaners are water, IPA (Isopropyl Alcohol) or Hexane. Do not use Ketone type materials (ex. Acetone), Ethyl alcohol, Toluene, Ethyl acid or Methyl chloride. It might produce a permanent damage to the polarizer due to chemical reaction.
- (e) If the liquid crystal material leaks from the panel (i.e. when broken ), it should be kept away from the eyes or mouth. In case of contact with hands, legs or clothes, it must be washed away thoroughly with soap.
- (f) Protect the module from static electricity, it may cause damage to the C-MOS Gate Array IC`s.
- (g) Use finger-stalls with soft gloves in order to keep display clean during the incoming inspection and assembly process.
- (h) Do not disassemble the module.
- (i) Pins of I/F connector must not be touched directly with bare hands.



### **8-3 STORAGE**

- (a) The module shall be stored in a dark place. It is prohibited to apply sunlight or fluorescent light during the store.

### **8-4 OPERATION**

- (a) Do not connect, or disconnect the module in the “Power On” mode.
- (b) Power supply should always be turned on/off by following item 7.3 “ SUPPLY VOLTAGE SEQUENZE “. (see specification of your model)
- (c) Module has high frequency circuits. Sufficient suppression of electromagnetic interference shall be done by system manufacturers. Grounding and shielding methods may be important to minimize the interference.

### **8-5 OTHERS**

- (a) Ultra-violet ray filter is necessary for outdoor operation.
- (b) Avoid condensation. It may result in improper operation or permanent damage.
- (c) Do not exceed the absolute maximum rating values (e.g. the supply voltage variation, input voltage variation, variation in part contents and environmental temperature and so on). Otherwise the module may be damaged.
- (d) If the module displays the same pattern continuously for a long period of time, image “sticking” can be seen on the screen. For proper operations avoid such conditions.
- (e) This module has its circuitry PCB's on the rear side. Please handle carefully in order to avoid any kind of stress.