

Industrial Solutions Flatpanel Technology

DESIGN FOR TFT COLOR LCD MODULE

Design No.	doh035_105
Revision	i-sft ↔ Rev. 02
	SPECIFICATIONS
Version	Internal Revision 0.1
Date	01.03.2004
Preliminary <input checked="" type="checkbox"/>	
Final <input type="checkbox"/>	
Buyer	

This typical design can be used to manufacture dedicated products at i-sft according to the mentioned specification. Please send us a RFQ for this design and stating the number of displays to be build. We will send a formal quote including a final specification. With your formal order please also send a written approval of the final specification. No further activities will start before formal order is processed and written approval of final specification is in!

1	DESCRIPTION.....	3
2	FEATURES.....	3
3	APPLICATIONS.....	3
4	STRUCTURE AND FUNCTIONS.....	3
5	OUTLINE OF CHARACTERISTICS.....	4
6	BLOCK DIAGRAM	5
7	SPECIFICATIONS	6
	7-1 GENERAL SPECIFICATIONS.....	6
	7-2 ABSOLUTE MAXIMUM RATINGS.....	6
	7-3 ELECTRICAL CHARACTERISTICS.....	7
	7-4 SUPPLY VOLTAGE SEQUENCE.....	8
	7-5 INTERFACE PIN CONNENCTION.....	9
	7-6 DISPLAY COLORS vs. INPUT DATA SIGNALS.....	11
	7-7 INPUT SIGNAL TIMING	12
	7-8 DISPLAY POSITION at HRV: L and VRV: L.....	17
	7-9 DEFECT SPECIFICTIONS.....	17
	7-10 OPTICAL CHARACTERISTICS.....	20
	7-11 INVERTER SPECIFICTIONS	23
	7-12 RELIEBILITY TEST 1	25
	7-13 MEASUREMENTS	26

1 DESCRIPTION

i-sft doh035_105 is a TFT (thin film transistor) active matrix colour liquid crystal display (LCD) comprising amorphous silicon TFT attached to each signal electrode, a driving circuit.

i-sft doh035_105 is an i-sft specific design consisting out of an i-sft specific third party manufactured LCD-Glass-Matrix with backlight (which is NOT available in retail), a specific backlight to drive the panel to surface 500 nit and an integrated inverter. The 26cm diagonal display area contains 640×480 pixels and can display 262,144 colours simultaneously.

2 FEATURES

- Backlight for 500 nit display surface
- Thin and light weight
- High contrast ratio, wide viewing angle, wide colour gamut
- Variable γ control
- Wide temperature range
- Accepting high shock and vibration levels
- Data enable function
- Fixable connector
- Minimized image sticking (ghost pictures)
- Integrated inverter for driving backlight
- Colour spectrum adjusted to sunlight

3 APPLICATIONS

Extreme Environments

4 STRUCTURE AND FUNCTIONS

A TFT colour LCD module comprises a TFT LCD panel, LSIs for driving liquid crystal. The TFT LCD panel is composed of a TFT array glass substrate superimposed on a colour filter glass substrate with liquid crystal filled in the narrow gap between two substrates.

RGB (Red, Green, Blue) data signals are sent to LCD panel drivers after modulation into suitable forms for active matrix addressing through signal processor.

Each of the liquid crystal cells acts as an electro-optical switch that controls the incident light transmission by a signal applied to a signal electrode through the TFT switch.

5 OUTLINE OF CHARACTERISTICS

Display area	211.7 mm (H) × 158.9 mm (V)
Drive system	a-Si TFT active matrix
Display colors	262,144 colours
Number of pixels	640 × 480
Pixel arrangement	RGB, vertical stripe
Pixel pitch	0.33 mm (H) × 0.33 mm (V)
Module size	271 mm (H) × 192 mm (V) × 27 mm (D)
Weight	1220 g (typ.)
Luminance	500 cd/m ² (typ.)
Dimming range	1:250
Contrast ratio	250:1 (typ.) *note
Colour gamut	50% (typ. at center, to NTSC) *note
Response time	15 ms (typ.), "white" to "black"
Transmittance	tbd
Incident light intensity	300,000 lux (max.) at the colour filter side 20,000 lux (max.) at the TFT side
Signal system	6-bit digital signals for each of RGB primary colours, synchronous signals (hsync, vsync), Dot clock (CLK)
Supply voltage	5.0 V or 3.3 V (Logic, LCD driving), 12 VDC for integrated Inverter
Scanning direction	Vertical scanning is normal/reverse Horizontal scanning is normal/reverse

*note: Measuring light conditions

Lamp:

Cold Cathode Fluorescent Lamp

Chromaticity coordinates:

(x = 0.320; y = 0.325) typ.

Luminance at backlight surface:

1500 cd/m²

6 BLOCK DIAGRAM

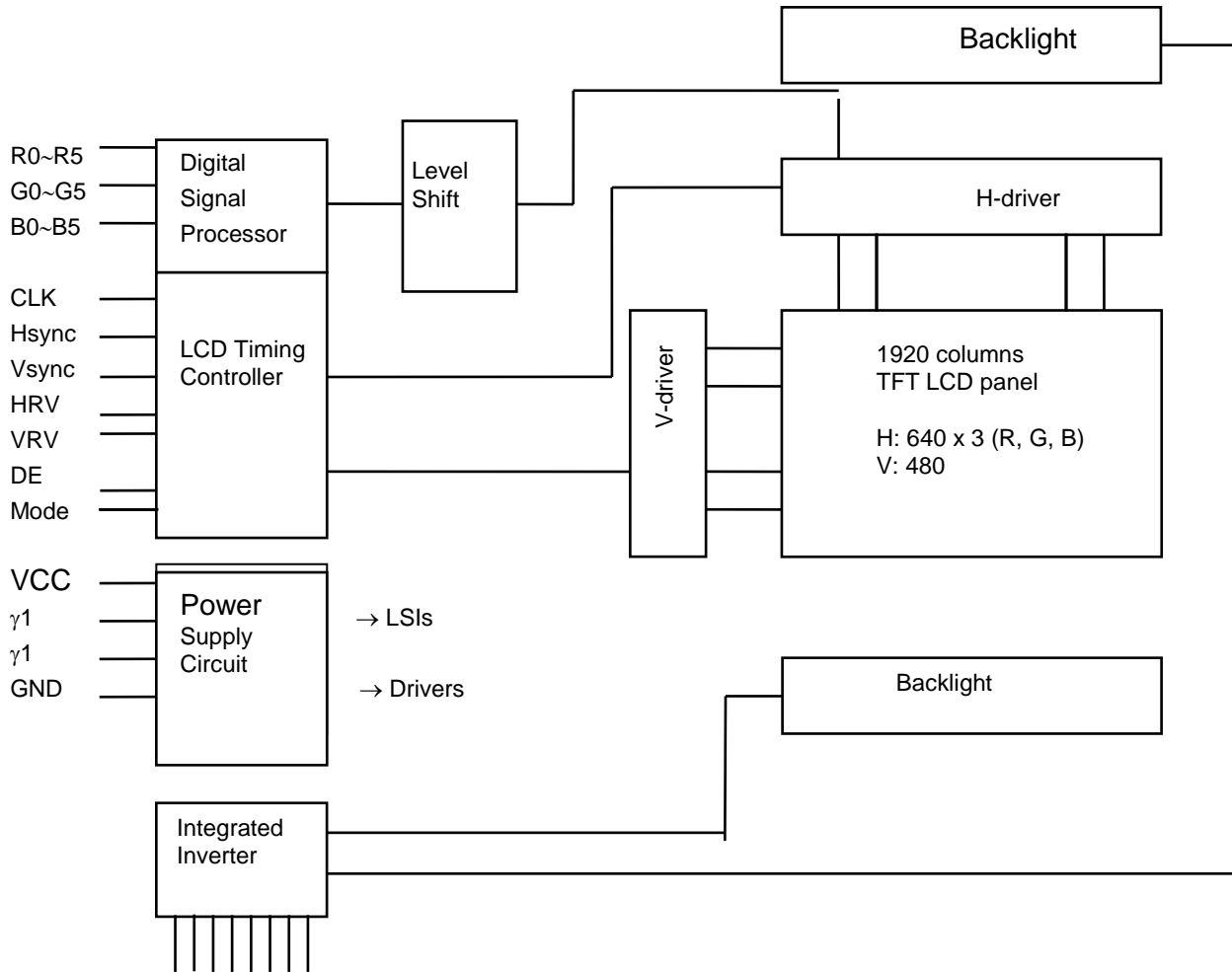

1 2 3 4 5 6 7 8

- 1,2: V_{inv}
- 3: remote on / off
- 4: digital dimming input
- 5: reference voltage output
- 6: analog dimming input
- 7,8: GND

7 SPECIFICATIONS

7-1 GENERAL SPECIFICATIONS

Item	Specifications	Unit
Module size	271 (H) × 192 (V) × 27 (D)	mm
Display area	211.7 (H) × 158.9 (V)	mm
Number of pixels	640×3 (H) × 480 (V)	pixel
Dot pitch	0.11 (H) × 0.33 (V)	mm
Pixel pitch	0.33 (H) × 0.33 (V)	mm
Pixel arrangement	RGB (Red, Green, Blue) vertical stripe	-
Display colours	262,144	color
Weight	1220 (typ.)	g

7-2 ABSOLUTE MAXIMUM RATINGS

Parameter	Symbol	Ratings	Unit	Remarks
Supply voltage inverter	V _{inv}	typ. 12 VDC (min. 9 VDC max. 15 VDC) *3	V	T _a = 25°C
Supply voltage	V _{cc}	-0.3 to 6.5	V	T _a = 25°C
Input voltage	V _I	-0.3 to 6.5	V	V _I – V _{cc} < 3.0
Low temperature storage	T _{ls}	-45	°C	
Low temperature operational	T _{lo}	-31 *1	°C	
High temperature storage	T _{hs}	85	°C	
High temperature operational	T _{ho}	85 *1	°C	
Storage temp.	T _{st}	-45 to 95	°C	int. design verify. test
Operation temp.	T _{op}	-40 to 95	°C	int. design verify. test
Humidity	RH	≤ 95% relative humidity *2	TA ≤ 40 °C	no condensation
		≤ 85% relative humidity *2	TA ≤ 50 °C	
		Absolute humidity shall not exceed TA = 50 °C 85% rel. humidity level *2	TA > 50 °C	
Incident light intensity	I _I	≤ 300k	lux	at backlight side
		≤ 20k		at TFT side

*1: measured at center display area (Front side)

*2: without any protection

*3: specified values for inverter valid for fixed input of 12 VDC only

7-3 ELECTRICAL CHARACTERISTICS

(1) Logic, LCD driving

Ta = 25°C

Parameter	Symbol	Min.	Typ.	Max.	Unit	Remarks
Supply voltage	V _{CC}	4.75 (3.0)	5.0 (3.3)	5.25 (3.6)	V	V _{CC} = 5.0 V (V _{CC} = 3.3 V)
Logic input "L" voltage	V _{IL}	0	-	V _{CC} x 0.3	V	CMOS level
Logic input "H" voltage	V _{IH}	V _{CC} x 0.7	-	5.25	V	
Supply current	I _{CC}	-	400 ‡ 1	500	mA	V _{CC} = 5.0 V
		-	(500)	600		(V _{CC} = 3.3 V)
Input current (Low) ‡ 2 V _I = 0V	I _{OL1}	-	10 ⁻⁵ (10 ⁻⁵)	10.0 (8.0)	µA	V _{CC} = 5.0 V
	I _{OL2}	-	-0.15 (-0.2)	-0.3 (-0.4)	µA	(V _{CC} = 3.3 V)
Input current (High) ‡ 2 V _I = V _{CC}	I _{OH1}	-	10 ⁻⁵ (10 ⁻⁵)	10.0 (8.0)	µA	V _{CC} = 5.0 V
	I _{OH2}	-	100 (70)	200 (150)	µA	(V _{CC} = 3.3 V)

‡ 1: Checker flag pattern (in EIAJ ED-2522)

‡ 2: I_{OL1}, I_{OH1} CLK, Hsync, Vsync, R0-R5, G0-G5, B0-B5, DE, MODE
 I_{OL2}, I_{OH2} HRV, VRV

7-4 SUPPLY VOLTAGE SEQUENCE

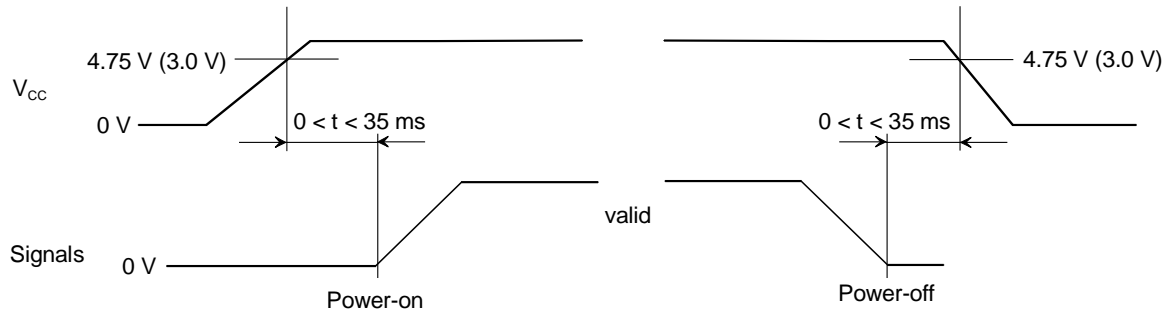

note 1: The supply voltage for input signals should be the same as V_{CC} .

note 2: Turn on the backlight within the LCD operation period. When the backlight turns on before LCD operation or the LCD operation turns off before the backlight turns off, the display becomes momentarily white.

note 3: When the power is off, please keep whole signals (Hsync, Vsync, CLK, DE, MODE and DATA) low level or high impedance.

7-5 INTERFACE PIN CONNENCTION

(1) Interface signals, power supply

Module side connector
CN1 : PS-34PE-D4LT1-SM1 (JAE)

Mating connector
PS-34SM-D4P1-1C

Pin No.	Symbol	Function
1	GND	Ground
2	CLK	Dot clock
3	Hsync	Horizontal sync
4	Vsync	Vertical sync
5	GND	Ground
6	R0	Red data (LSB)
7	R1	Red data
8	R2	Red data
9	R3	Red data
10	R4	Red data
11	R5	Red data (MSB)
12	GND	Ground
13	G0	Green data (LSB)
14	G1	Green data
15	G2	Green data
16	G3	Green data
17	G4	Green data

Pin No.	Symbol	Function
18	G5	Green data (MSB)
19	GND	Ground
20	B0	Blue data (LSB)
21	B1	Blue data
22	B2	Blue data
23	B3	Blue data
24	B4	Blue data
25	B5	Blue data (MSB)
26	GND	Ground
27	DE	Data enable
28	Vcc	Power supply
29	Vcc	Power supply
30	MODE	note 1
31	HRV	note 2
32	VRV	note 3
33	γ 1	note 4
34	γ 2	note 5

note:

- 1) MODE: L or OPEN = DE mode
H = fixed timing mode
- 2) HRV *: L or OPEN = scanning is normal
H = scanning is reverse
47 K Ω at pull down (old 1 K Ω)
- 3) VRV *: L or OPEN = scanning is normal
H = scanning is reverse
47 K Ω at pull down (old 1 K Ω)
*see from TFT side

LSB: Least Significant Bit

MSB: Most Significant Bit

Input current

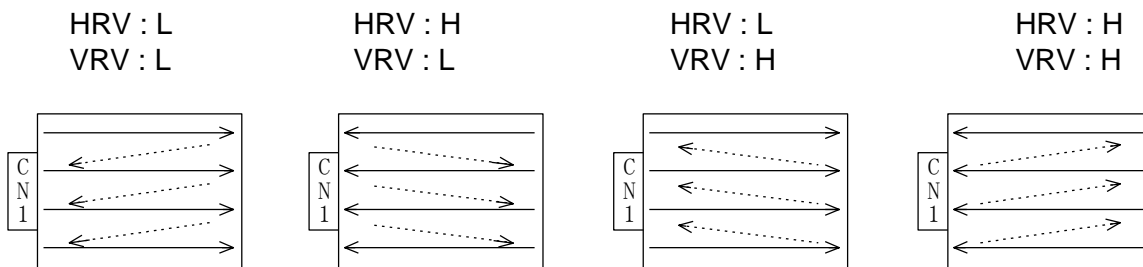
Vin = 0 V -0,15 μ Vcc 5.0 V-0,2 μ Vcc 3.3 VVin = Vcc 100 μ Vcc 5.0 V70 μ Vcc 3.3 V

- 4) γ_1, γ_2 : Adjustment of γ correction. The pins 33 " γ_1 " and 34 " γ_2 " should be left open for best optical performance! (otherwise the optical performance will be programmed for special use).



Variable resistor for special use ONLY!
Mating VR: 2.2 k Ω \pm 5%

- 5) GND is connected to frame of the LCD module.



7-6 DISPLAY COLORS vs. INPUT DATA SIGNALS

Display colors		Data signal (0: Low level, 1: High level)																	
		R5	R4	R3	R2	R1	R0	G5	G4	G3	G2	G1	G0	B5	B4	B3	B2	B1	B0
Basic colors	Black	0	0	0	0	0	0	0	0	0	0	0	0	0	0	0	0	0	0
	Blue	0	0	0	0	0	0	0	0	0	0	0	0	1	1	1	1	1	1
	Red	1	1	1	1	1	1	0	0	0	0	0	0	0	0	0	0	0	0
	Magenta	1	1	1	1	1	1	0	0	0	0	0	0	1	1	1	1	1	1
	Green	0	0	0	0	0	0	1	1	1	1	1	1	0	0	0	0	0	0
	Cyan	0	0	0	0	0	0	1	1	1	1	1	1	1	1	1	1	1	1
	Yellow	1	1	1	1	1	1	1	1	1	1	1	1	0	0	0	0	0	0
	White	1	1	1	1	1	1	1	1	1	1	1	1	1	1	1	1	1	1
Red grayscale	Black	0	0	0	0	0	0	0	0	0	0	0	0	0	0	0	0	0	0
	dark	0	0	0	0	0	1	0	0	0	0	0	0	0	0	0	0	0	0
	↑																		
	↓																		
	bright	1	1	1	1	0	1	0	0	0	0	0	0	0	0	0	0	0	0
	Red	1	1	1	1	1	0	0	0	0	0	0	0	0	0	0	0	0	0
Green grayscale	Black	0	0	0	0	0	0	0	0	0	0	0	0	0	0	0	0	0	0
	dark	0	0	0	0	0	0	0	0	0	0	1	0	0	0	0	0	0	0
	↑																		
	↓																		
	bright	0	0	0	0	0	0	1	1	1	1	0	1	0	0	0	0	0	0
	Green	0	0	0	0	0	0	1	1	1	1	1	1	0	0	0	0	0	0
Blue grayscale	Black	0	0	0	0	0	0	0	0	0	0	0	0	0	0	0	0	0	0
	dark	0	0	0	0	0	0	0	0	0	0	0	0	0	0	0	0	1	0
	↑																		
	↓																		
	bright	0	0	0	0	0	0	0	0	0	0	0	0	1	1	1	1	0	1
	Blue	0	0	0	0	0	0	0	0	0	0	0	0	1	1	1	1	1	1

note: colors are developed in combination with 6 bit signals (64 steps in grayscale) of each primary red, green and blue color.

This process can result in up to 262, 144 (64x64x64) colors.

7-7 INPUT SIGNAL TIMING**(1) INPUT SIGNAL SPECIFICATIONS**

Parameter		Symbol	MIN.	TYP.	MAX.	Unit	Remarks
CLK	Frequency	1/Tc	21.0	25.175	29.0	MHz	39.722ns (TYP.)
	Duty	Tch/Tc	0.4	0.5	0.6		
	Rise, Fall	Tcrf	-	-	10	ns	
Hsync	Period	Th	30.0	31.778	33.6	μs	31.469kHz (TYP.)
			-	800	-	CLK	
	Display period	Thd	640			CLK	
	Front-porch	Thf	-	16	-	CLK	fixed timing mode
			4	16	-	CLK	DE mode
	Pulse width	Thp *)	10	96	140	CLK	fixed timing mode
			10	96	-	CLK	DE mode
	Back-porch	Thb *)	4	48	134	CLK	fixed timing mode
			4	48	-	CLK	DE mode
	*) Thp-Thb		144			CLK	fixed timing mode
			14	144	-	CLK	DE mode
	CLK-Hsync timing	Thch	12	-	-	ns	
	Hsync-CLK timing	Thcs	8	-	-	ns	
Hsync-Vsync timing	Tvh	1	-	-	CLK	1CLK=39,722ns (TYP.)	
Vsync-Hsync timing	Tvs	30	-	-	ns		
Rise, Fall	Thrf	-	-	10	ns		
Vsync	Period	Tv	16.1	16.683	17.2	ms	59.94Hz (TYP.)
			-	525	-	H	
	Display Period	Tvd	480			H	
	Front-porch	Tvf	-	12	-	H	fixed timing mode
			1	12	-	H	DE mode
	Pulse width	Tvp *)	1	2	29	H	fixed timing mode
			1	2	-	H	DE mode
	Back-porch	Tvb *)	4	31	32	H	fixed timing mode
			4	31	-	H	DE mode
*) Tvp+Tvb		33			H	fixed timing mode	
		5	33	-	H	DE mode	
Rise, Fall	Tvrf	-	-	10	ns		
DATA							
R0 – R5	CLK-DATA timing	Tds	8	-	-	ns	
G0 – G5	DATA-CLK timing	Tdh	12	-	-	ns	
B0 – B5	Rise, Fall	Tdrf	-	-	10	ns	
DE	DE-CLK timing	Tes	8	-	-	ns	DE mode
	CLK-DE timing	The	12	-	-	ns	
	Rise, Fall	Terf	-	-	10	ns	

note: All parameters should be kept within the specified range.

(2) DEFINITION OF INPUT SIGNAL TIMING

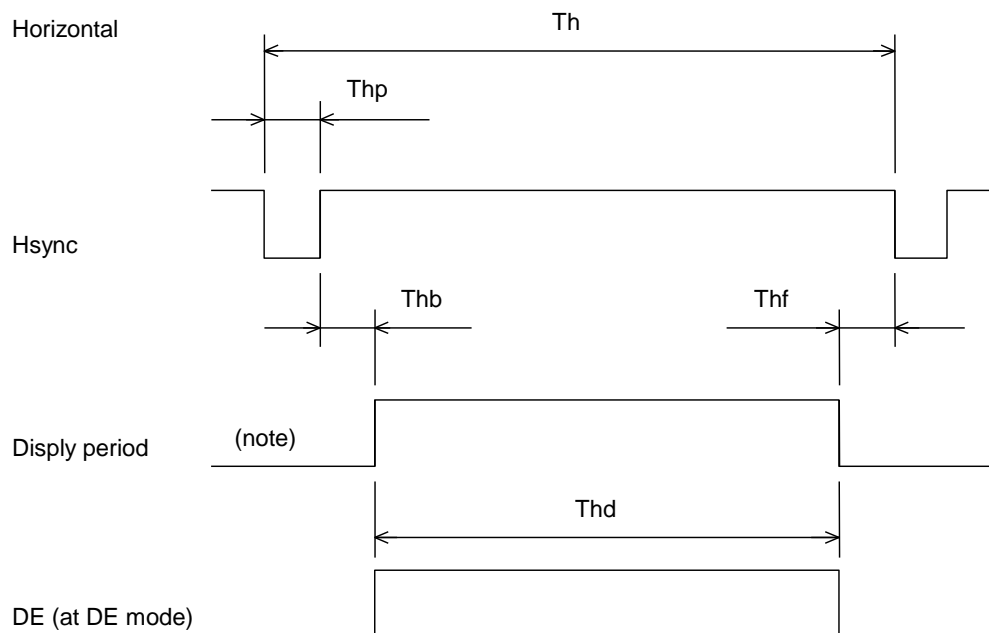
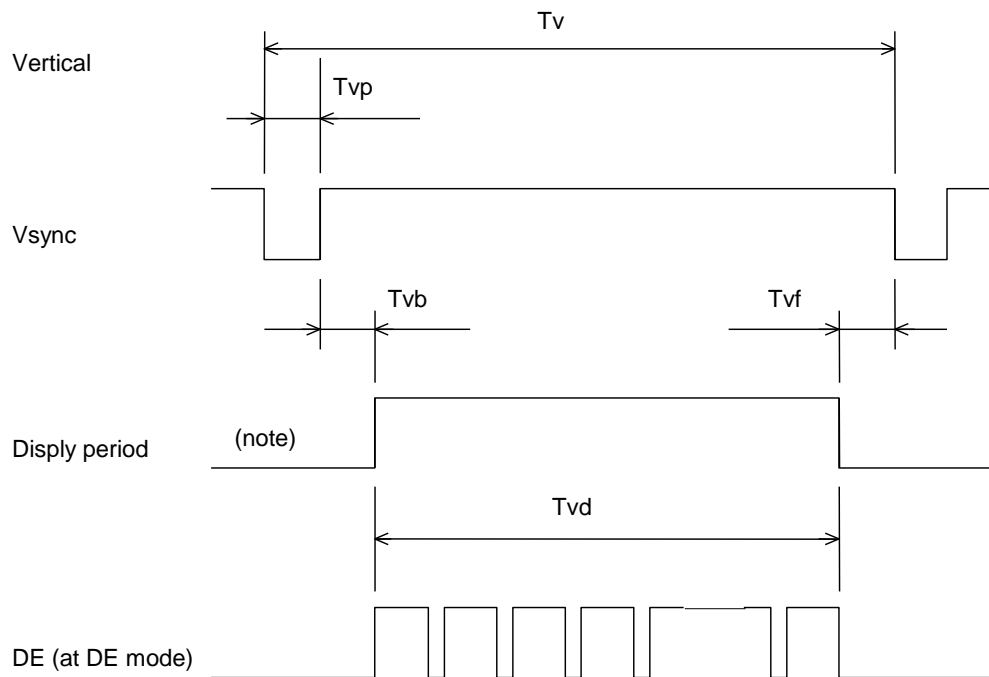

note: these signals do not exist

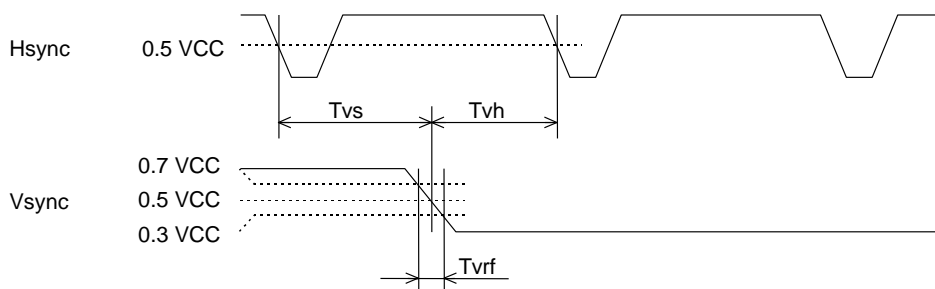
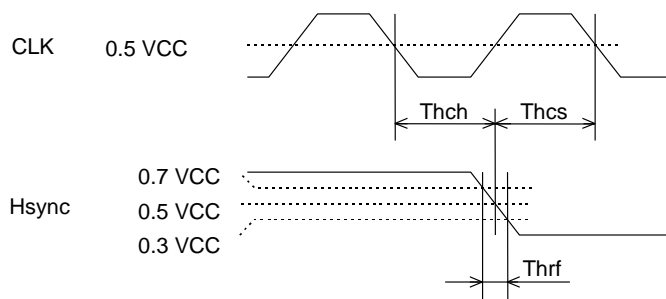
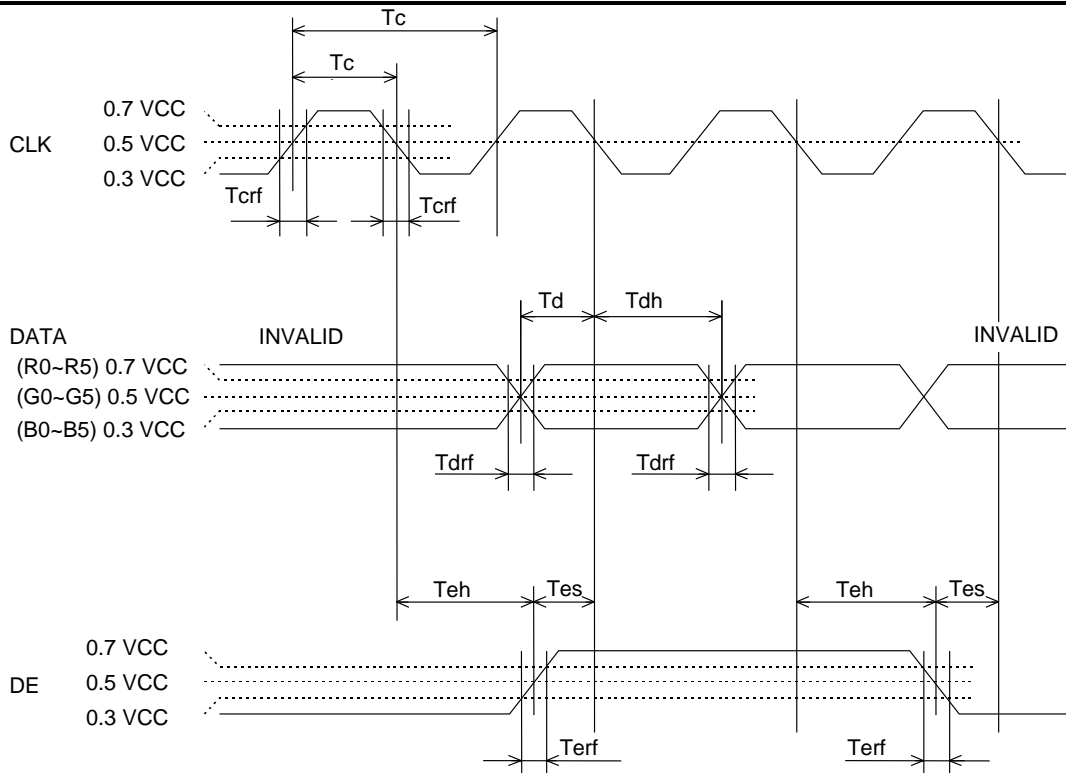

(3) INPUT SIGNAL TIMING CHART

a. fixed timing mode

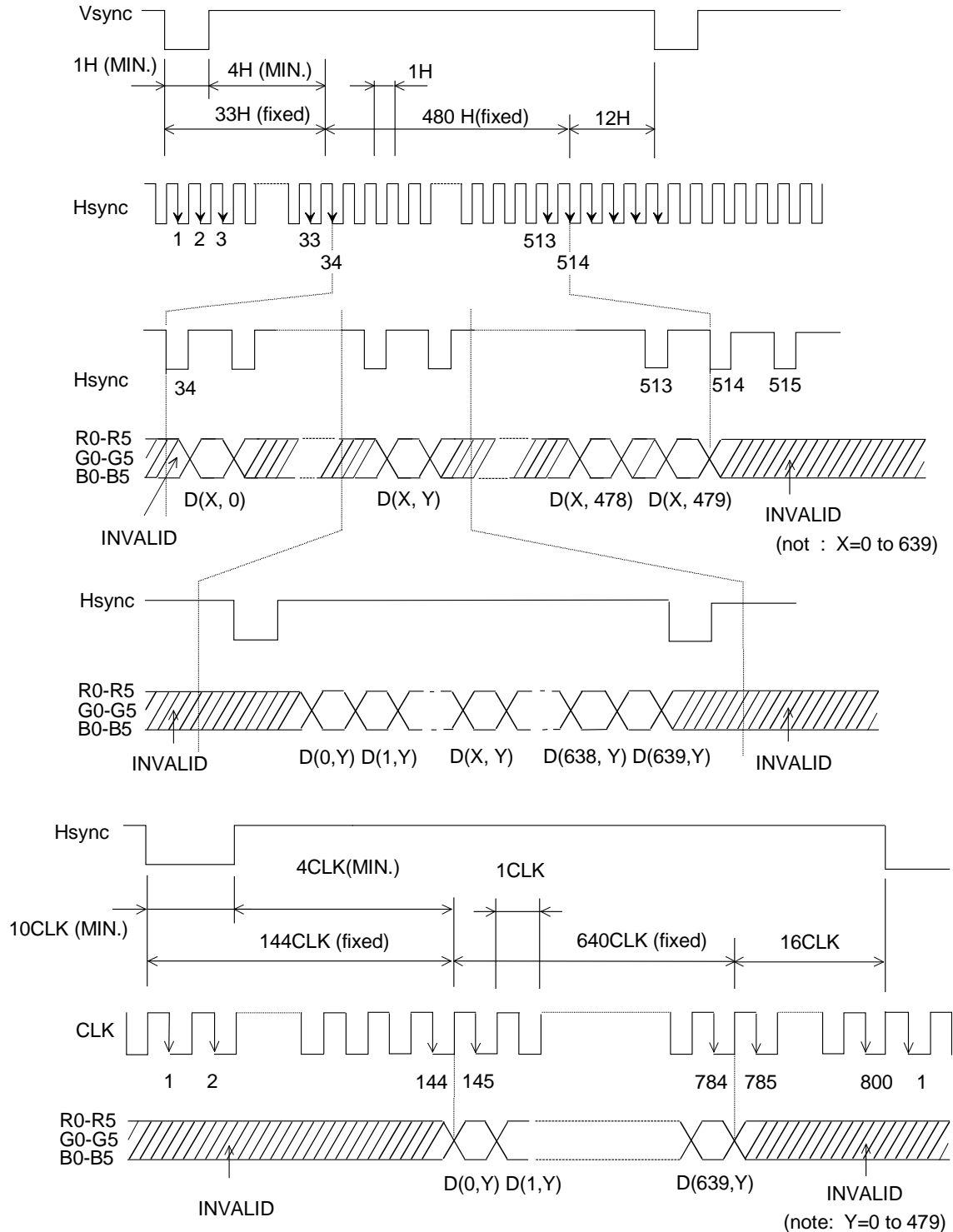

b. DE mode

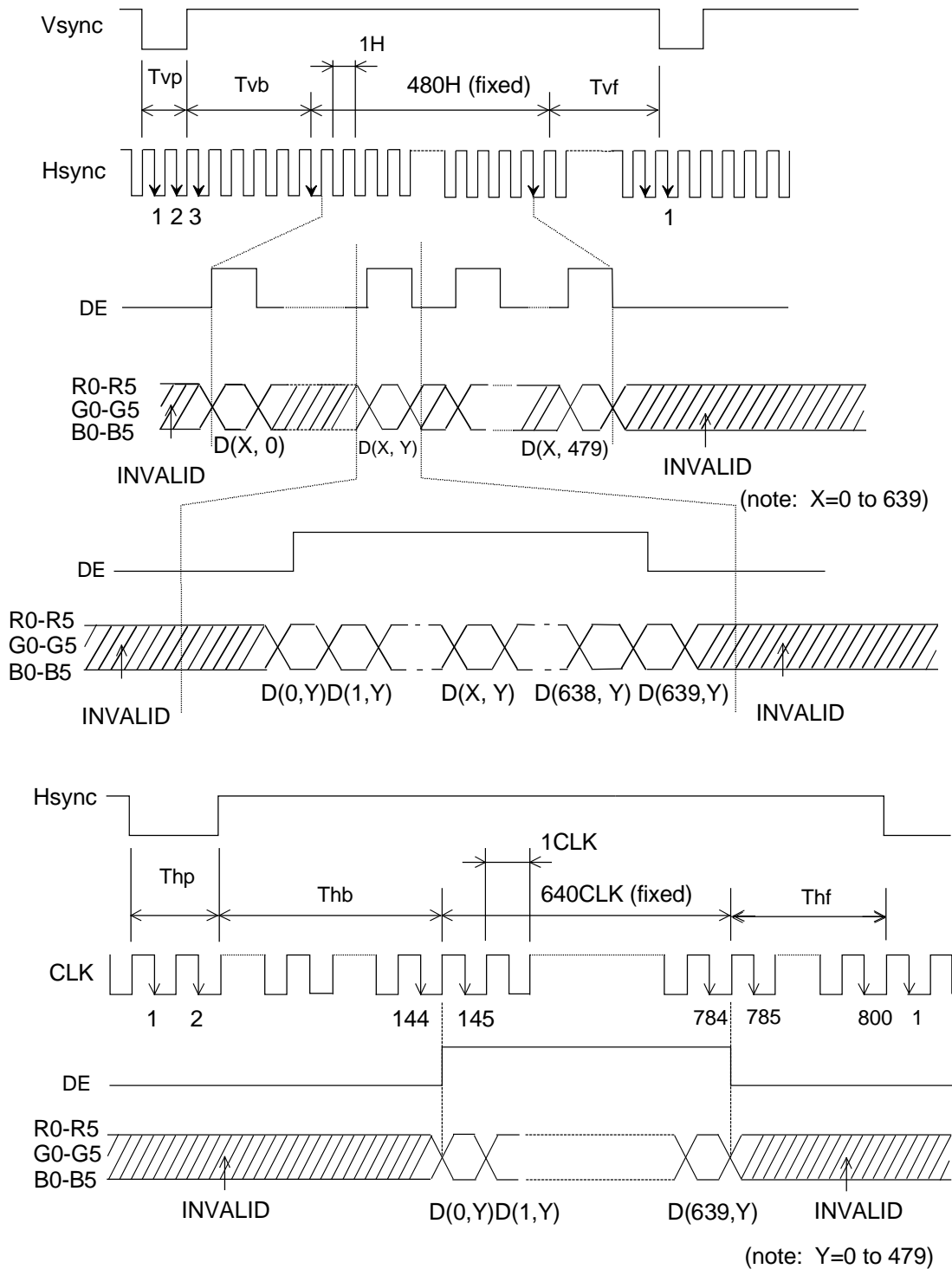

7-8 DISPLAY POSITION

at HRV: L and VRV: L

D (0,0)	D (1,0)		D (X,0)		D (638,0)	D (639,0)
D (0,1)	D (1,1)		D (X,1)		D (638,1)	D (639,1)
D (0,Y)	D (1,Y)		D (X,Y)		D (638,Y)	D (639,Y)
D (0,478)	D (1,478)		D (X,478)		D (638,478)	D (639,478)
D (0,479)	D (1,479)		D (X,479)		D (638,479)	D (639,479)

7-9 DEFECT SPECIFICATIONS**a. Inspection conditions**

Distance: The distance between the inspector's eye and the LCD panel is 20cm.

Illumination: The distance between a 20-W fluorescent lamp and the LCD panel is 25 – 30 cm.

Temperature: Room temperature is 25 °C ± 5 °C.

Viewing angle:

Display specifications: $-20^\circ \leq \theta_x \leq +20^\circ$, $0^\circ \leq \theta_y \leq +20^\circ$

Appearance specifications: $-45^\circ \leq \theta_x \leq +45^\circ$, $-45^\circ \leq \theta_y \leq +45^\circ$

Measuring light conditions:

Lamp: Cold Cathode Fluorescent Lamp

Chromaticity coordinates (x = 0.320, y = 0.325) typ.

Luminance of backlight surface for inspection: 1500 cd/m².

b. Display specifications

Item	Specifications			
Line defect	Not allowed			
Luminous dots *1	Colour	Brightness	Distance between same colour dots	Quantity
	Red, Green	F + H	-	$R + G \leq 6$
		F	-	$R \leq 6, G \leq 3$
	Blue	F + H	-	≤ 6
		F	-	≤ 6
	Red, Green, Blue	F	$\leq 6.5 \text{ mm}$ *4	$R, G, B \leq 0$
Linked two or more dots *3			$R, G, B \leq 0$	
Dark dots *2	Colour	Distance between dark dots		Quantity
	Black	-		$R + G + B \leq 16$ $R, G, B \leq 7$
		Linked two dots	*3	$\leq 1 \text{ pair}$
		Linked three or more dots	*3	≤ 0
		$\leq 6.5 \text{ mm}$	*4	≤ 0

*1 F: Full luminous dots (Bright point independent of viewing angle)

H: Half luminous dots (Bright point dependent on viewing angle)

Luminous dots are measured while the screen is black.

*2 Dark dots are measured while the screen is illuminated with Red, Green, or Blue.

*3 Linkage means linked two or more dots.

(■ : Luminous or Dark dot)

To be counted



To be uncounted



*4 $\leq 6.5 \text{ mm}$ is considered with:

(■ : Luminous or Dark dot)

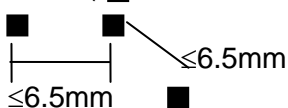

	To be counted	To be uncounted
Luminous dots	Same color	Different color
Dark dots	Same screen	Different screen

*5 The dot-amounts of linkage and $<6.5 \text{ mm}$ are counted when the dots are only full luminous.

c. Appearance specifications

Item	Specifications		
	Measurement criteria	Quantity	
Other objects Stains Dust (dot shape)	Average diameter (\varnothing)mm		
	$\varnothing \leq 0.2$	all allowed	
	$0.2 < \varnothing < 0.3$	≤ 10 points	
	$0.3 < \varnothing \leq 0.5$	≤ 3 points	
	$0.5 < \varnothing$ Linked other objects	0 point	
Other objects Stains Dust (line shape)	Width(W) mm	Length(L) mm	
	$W \leq 0.05$	-	
	$0.05 \leq W \leq 0.1$	$L < 0.7$	≤ 4 points
		$0.7 \leq L \leq 1.0$	
	$0.1 < W$	-	0 point
Polarizer Bubbles	Average diameter(\varnothing) mm		
Wrinkles Dent	$\varnothing \leq 0.5$	< 2 points	
Panel dent	$\varnothing \leq 0.5$	< 2 points	
Polarizer scratch	Remarkable scratches	0 point	
Form	Specified labels and parts are put		

The relevant data for the values above are only valid under conditions described at 7-9 "a".

7-10 OPTICAL CHARACTERISTICS

Ta = 25 °C ± 5°C note 1

Parameter		Symbol	Condition	Min.	Typ.	Max.	Unit	Remark
Viewing angle range	Horizontal	∅x+	CR>5, ∅y = ±0°	-	80	-	deg.	
		∅x-	CR>5, ∅y = ±0°	-	80	-	deg.	note 2
	Vertical	∅y+	CR>5, ∅x = ±0°	-	45	-	deg.	
		∅y-	CR>5, ∅x = ±0°	-	80	-	deg.	
Contrast ratio		CR	∅y=-5°, ∅x=±0°	-	250	-	-	note 3
Response time		tpd	white to black	-	15	-	ms	note 4
			black to white	-	35	-		
Luminance (center of screen)		Lw	at center		500		cd/m ²	note 6
Dimming range		DR			1:250			
Colour gamut		C	at center, to NTSC	40	50	-	%	note 5
Chromaticity	Red	Rx	at center	-	0,594	-	-	
		Ry		-	0,372	-	-	
	Green	Gx	“	-	0,343	-	-	note 5
		Gy		-	0,560	-	-	
	Blue	Bx	“	-	0,171	-	-	
		By		-	0,191	-	-	
White	Wx	“	-	0,361	-	-		
	Wy		-	0,368	-	-		
γ correction		γ	γ1-γ2 :0 Ω	-	tbd	-	-	-
			γ1-γ2 :2 kΩ	-	tbd	-	-	-

Typical DESIGN

- note 1: $V_{cc} = 5.0\text{ V}$
- note 2: Definitions of viewing angle are as follows. (matrix facing up, connector on the right side)

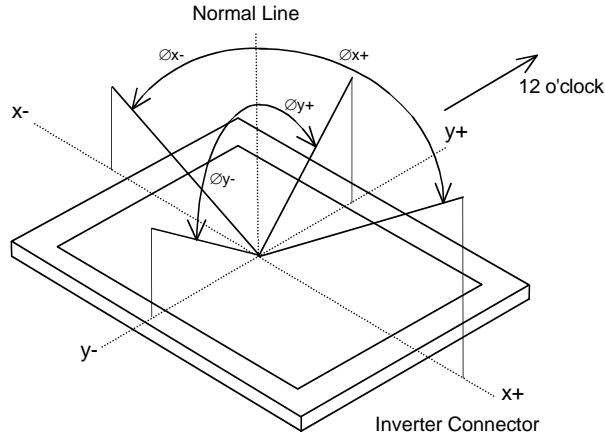

- note 3: The contrast ratio is calculated by using the following formula:

$\text{Contrast ratio} = \frac{\text{Brightness (Luminance) with all pixels in "White"}}{\text{Brightness (Luminance) with all pixels in "Black"}}$

the brightness is measured in darkroom.

- note 4: Definition of response time is as follows.
Photodetector output signal is measured when the brightness changes "white" to "black". Response time is the time between 10% and 90% of the photodetector output amplitude.

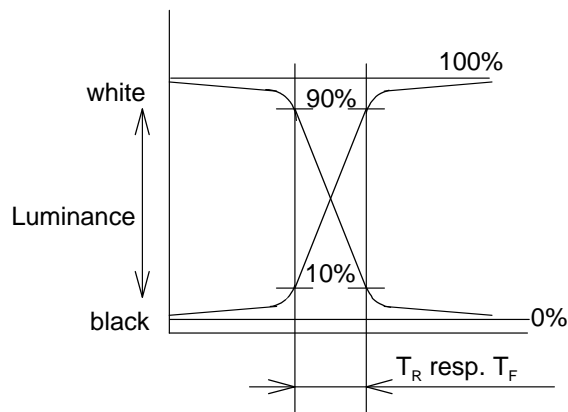

Reference data
 $T_a = 0^\circ\text{C}$

white to black	tpd = 15 ms typ.
black to white	tpd = 35 ms typ.

- note 5: For the measurement of color gamut and chromaticity, transmittance, use a lamp with a color temperature of 6000 K and a luminance of 1500 cd/m^2 .
The chromaticity value is: $x = 0.320$, $y = 0.325$.
- note 6: Brightness measurements setup
The measurement should be executed in a dark room 30 min. after lightning the backlight. Matrix: off state. The brightness is measured in the center of the screen.
Environment condition: $T = 25 \pm 2 \text{ }^\circ\text{C}$, it has to be assured that a sufficient heat flow / air circulation is given

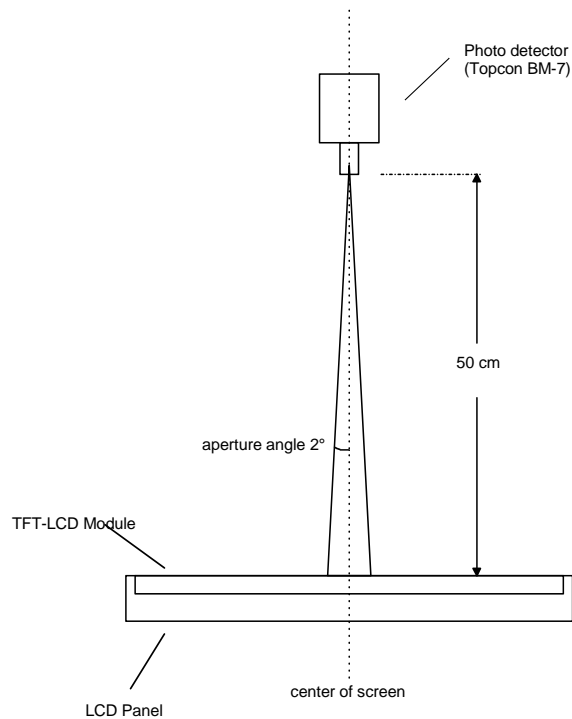

7-11 INVERTER SPECIFICATIONS

a. PIN CONNENCTION

Connector (Series): JST S8B-PH-SM3-TBc

Corresponding connector: housing JST PHR-8, contacts JST SPH-002T-P0.5S

Pin #	Description	Value
1	Supply voltage for Inverter	typ. 12 VDC / 1,6 A *1
2	Supply voltage for Inverter	typ. 12 VDC / 1,6 A *1
3	Remote on / off	n.c. -> On *2 GND -> Off
4	Digital dimming input	PWM, TTL – Level
5	Reference voltage output For dimming with variable resistor	5 V 4K7
6	Analog dimming input	0-5 VDC *3
7	Ground	GND *1
8	Ground	GND *1

Attention: depending on source and temperature, when switching on, the inverter current can be much higher (see separate application note)

*1 for connection use both pin 1 and 2 parallel and pin 7 and 8 parallel

*2 n.c.: no connection (leave pin open)

*3 If no dimming is required, you have to short pin 6 and pin 5 for maximum brightness, 0 VDC= dark, 5 VDC= bright

b. INVERTER CONNENCTIONS

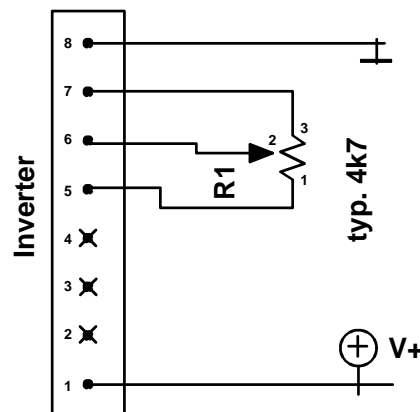

I. Dimming with variable Resistor (pin 7: 0 V)

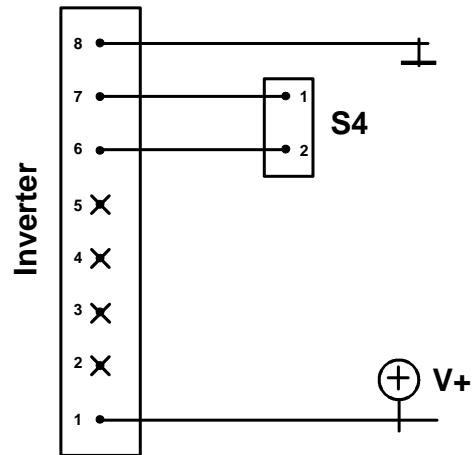

II. Dimming with variable analog DC voltage. Variable voltage 0 to 5 VDC (pin 7: 0 V)

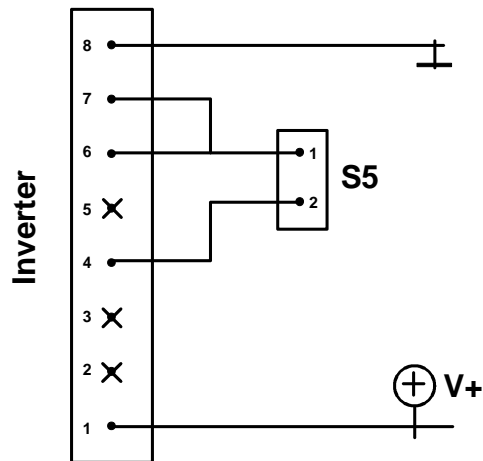

III. Digital Dimming with PWM control 0 to 100% PWM, PWM 200-1000 Hz; TTL-Level (pin 7: 0 V)

7-12 RELIABILITY TEST 1

No.	Test Item	Number	Test Condition	Judgement
1.	High Temperature (operation)		will be added	
2.	High Temperature / Humidity (operation)		will be added	
3.	Thermal shock (operation)		will be added	
4.	Heat Cycle (operation)		will be added	
5.	Vibration (operation)	5p	1. 4 Hz....21 mmp-p 4-150 Hz..3G 1 minute/cycle, X,Y,Z 6 direction sinewave, Log sweep, 25 ± 5°C 2. 20 times each direction Display data is black. *4	*1
6.	Mechanical Shock (operation)	5p	1. 100 G, 11 ms X, Y, Z direction Half sinwave, 25 ± 5°C 2. 5 times each direction 3. Display data is black. *4	*1 *2
7.	ESD (non-operation)	5p	150 PF, 150 Ω, +10 kV 9 places on a panel *3 10 times each place at 1sec. intervals	*1
8.	Drop Test (non-operation)	1 box	Drop packaged modules to concrete floor from 70 cm high, 3 times each face.	*1

*1: Display function

*2: Physical damage

*3: Discharge points are shown in the figure

*4: all pixel are "ON"

1	2	3
4	5	6
7	8	9

Reliability tests for design check

			under calculation	

7-13 MEASUREMENTS

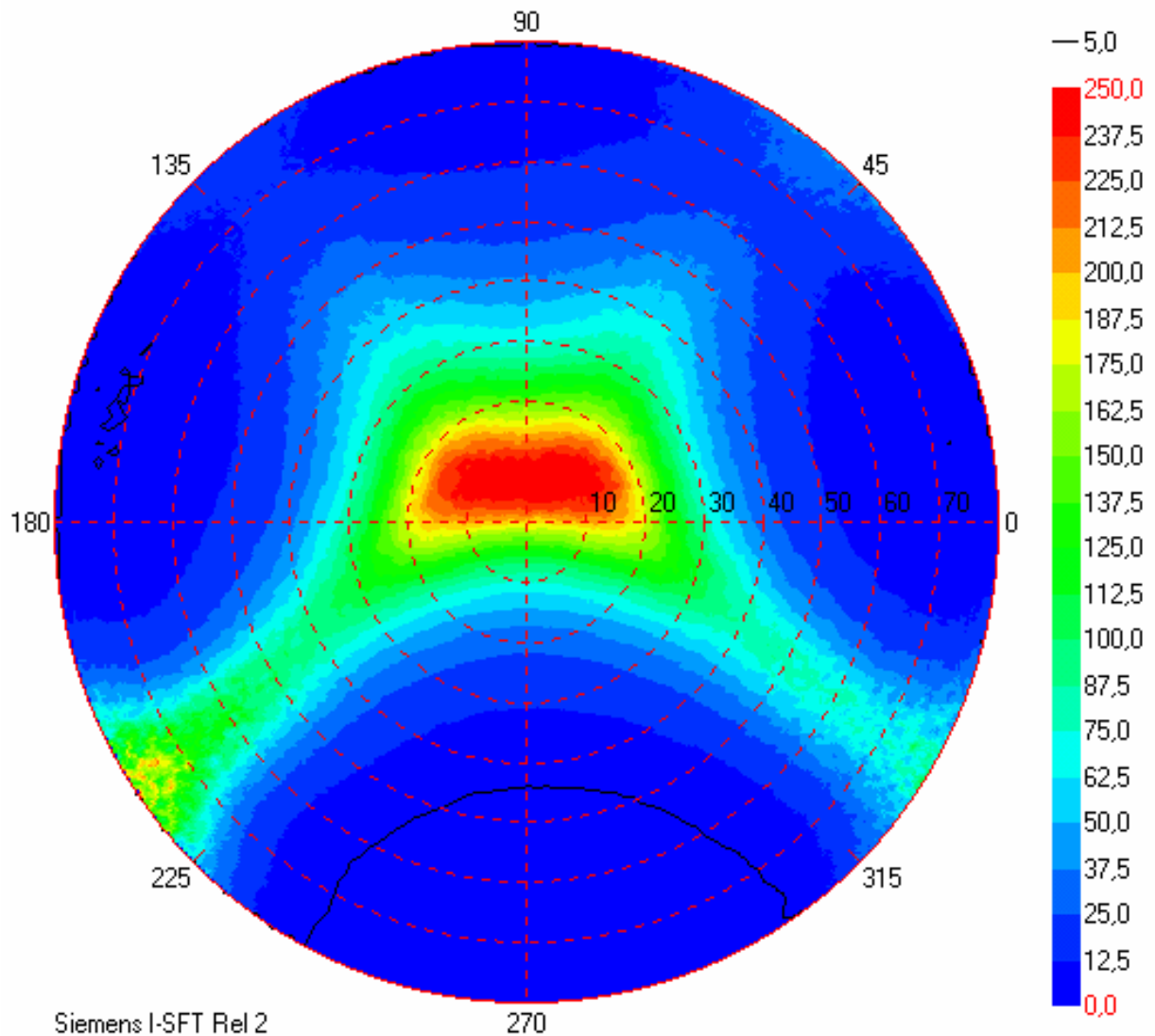

Typical measurement for i-sft Rel 2 (Display orientation: connector points to the left)

This omni-directional plot shows contrast ratio vs. viewing angle in range of left/right 80° / 80° and top/down 80° / 80°.

The different colours represent the contrast from 0 contrast (dark blue) to 250:1 contrast (bright red)

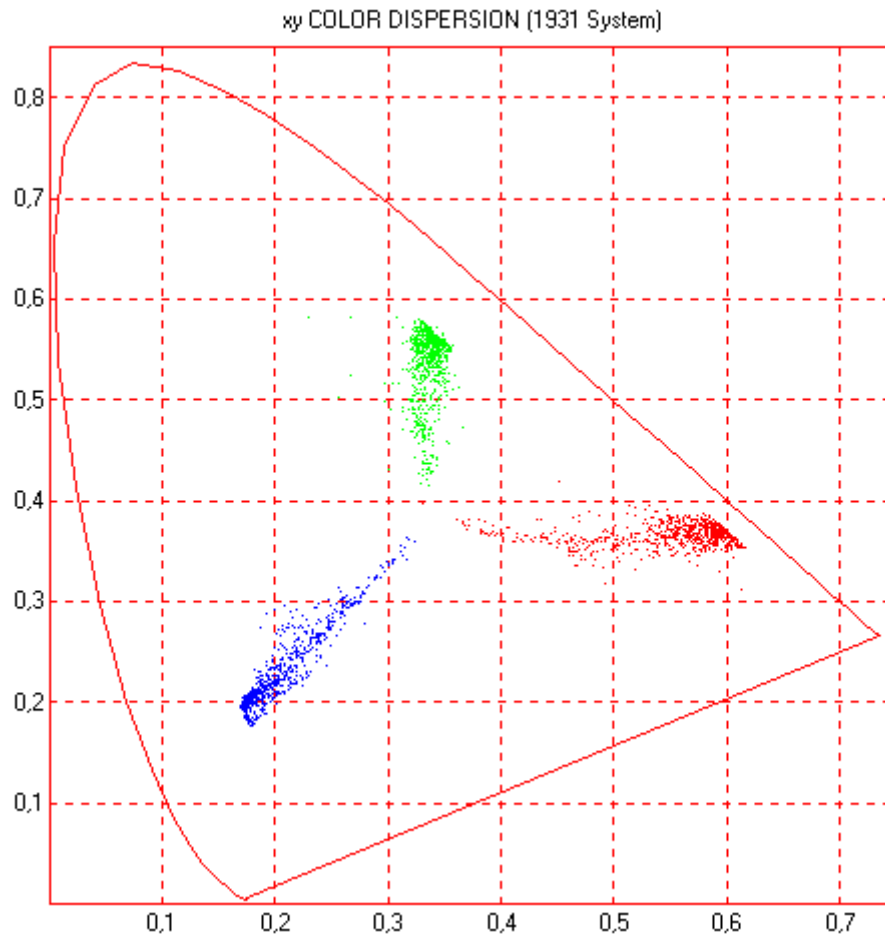

This plot shows the distribution of color coordinates for red, green and blue over the complete viewing angle of left / right $80^\circ / 80^\circ$ and top / down $80^\circ / 80^\circ$.